

R030.2015

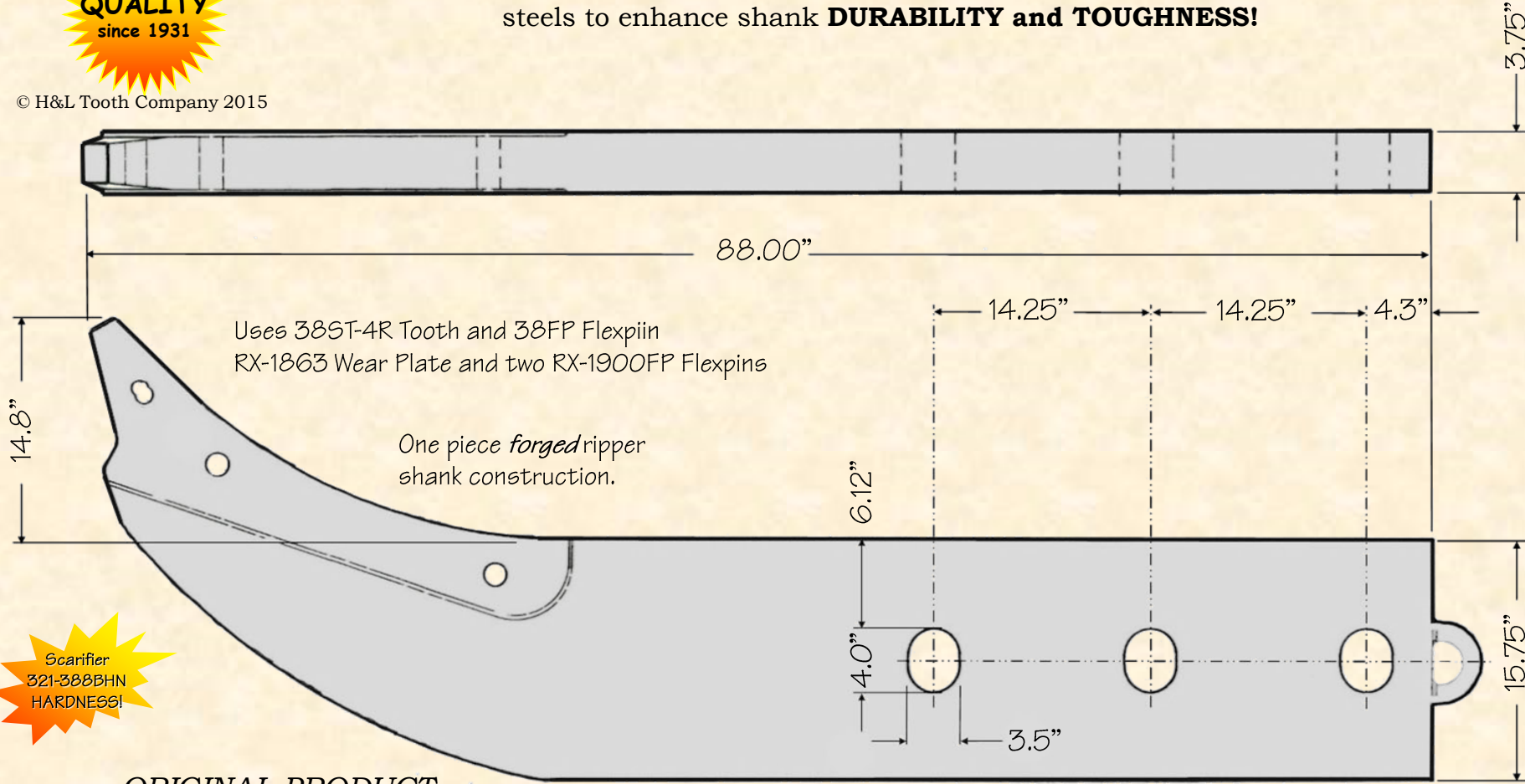

H&L Style RV-867088-YC-38 Rippers are produced from Chrom-Moly-Nickel grade alloy steels to enhance shank **DURABILITY and TOUGHNESS!**

© H&L Tooth Company 2015



ORIGINAL PRODUCT

H&L® TOOTH COMPANY

Factory Direct Made in Tulsa, Oklahoma

RV-867088-YC-38

Ripper Shank

1485.0#/673.60kgs.

H&L Tooth Company History since 1931:

This H&L's style RV-867088-YC-38 Uniforged ripping shank replacement for HL-195-79-51151, Komatsu Model D375.

H&L design uses the 38-Series tooth system was engineered and introduced by the H&L Tooth Company in 1990.

H&L products meet or exceeds all OEM standards.