

R091.2016



© H&L Tooth Company 2016

H&L's Cat Style HL-104-9277 Rippers are produced from Chrom-Moly-Nickel grade alloy steels to enhance shank **DURABILITY and TOUGHNESS!**

Uses (R550) CX-6Y-3552 Tooth with HL-6Y-1205 and HL-9N-4245 Pin and Retainer HL-9N-4621 Wear Plate with two HL-6Y-1205 and HL-9N-4245 Pins and Retainers.

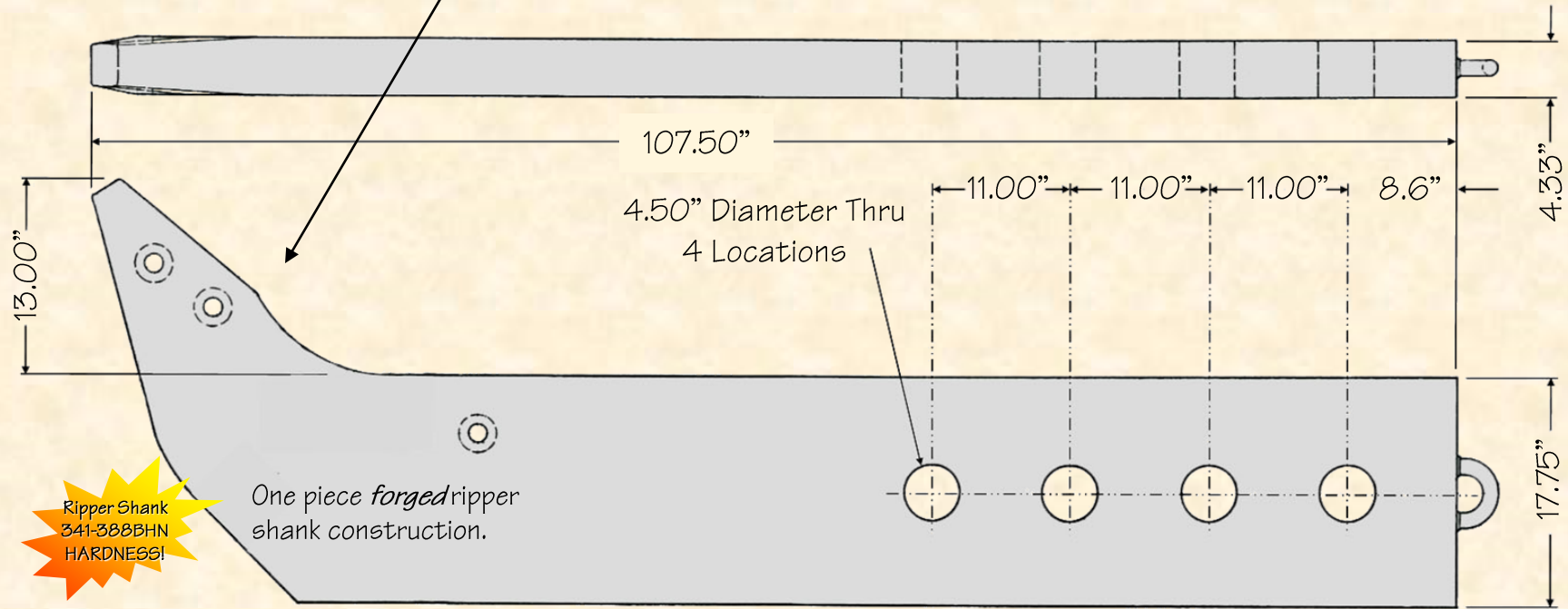

ORIGINAL PRODUCT

**H&L® TOOTH COMPANY**

Factory Direct Made in Tulsa, Oklahoma

**HL-104-9277**

Ripper Shank

2180.0#/1988.8kgs.

*H&L Tooth Company History since 1931:*

*This H&L's Cat style HL-104-9277 ripping shank is a replacement for Caterpillar's Model D11N and D11R Dozers. This shank uses the H&L's R-550 Series tooth system. Ripper shank was engineered and introduced by the H&L Tooth Company as a forged shank in 2002.*

*H&L products meet or exceeds all OEM standards.*