

R104.2016

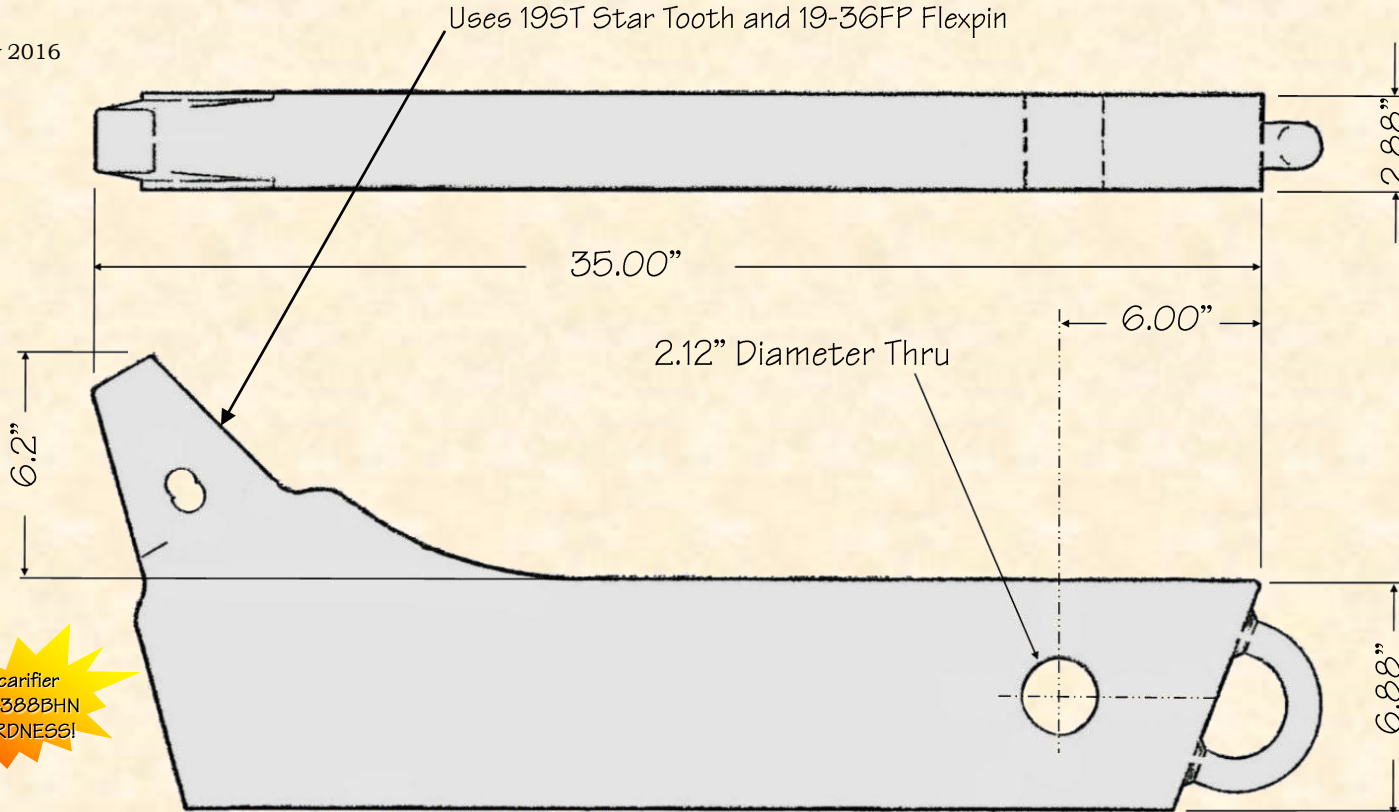

© H&L Tooth Company 2016

H&L's Style R-515-19 Rippers are produced from Chrom-Moly-Nickel grade alloy steels to enhance shank **DURABILITY and TOUGHNESS!**



ORIGINAL PRODUCT

H&L[®] TOOTH COMPANY

Factory Direct Made in Tulsa, Oklahoma

R-515-19

Ripper Shank

190.0#/186.2kgs.

H&L Tooth Company History since 1931:

This H&L's style R-515-19 ripping shank is designed to replace Caterpillar part number 7J-6671, fitting Model 983.

H&L ripper shank uses the H&L 19-Series tooth system. Original ripper shank was engineered and introduced by the H&L Tooth Company in 1975.

H&L products meet or exceeds all OEM standards.