

R105.2016

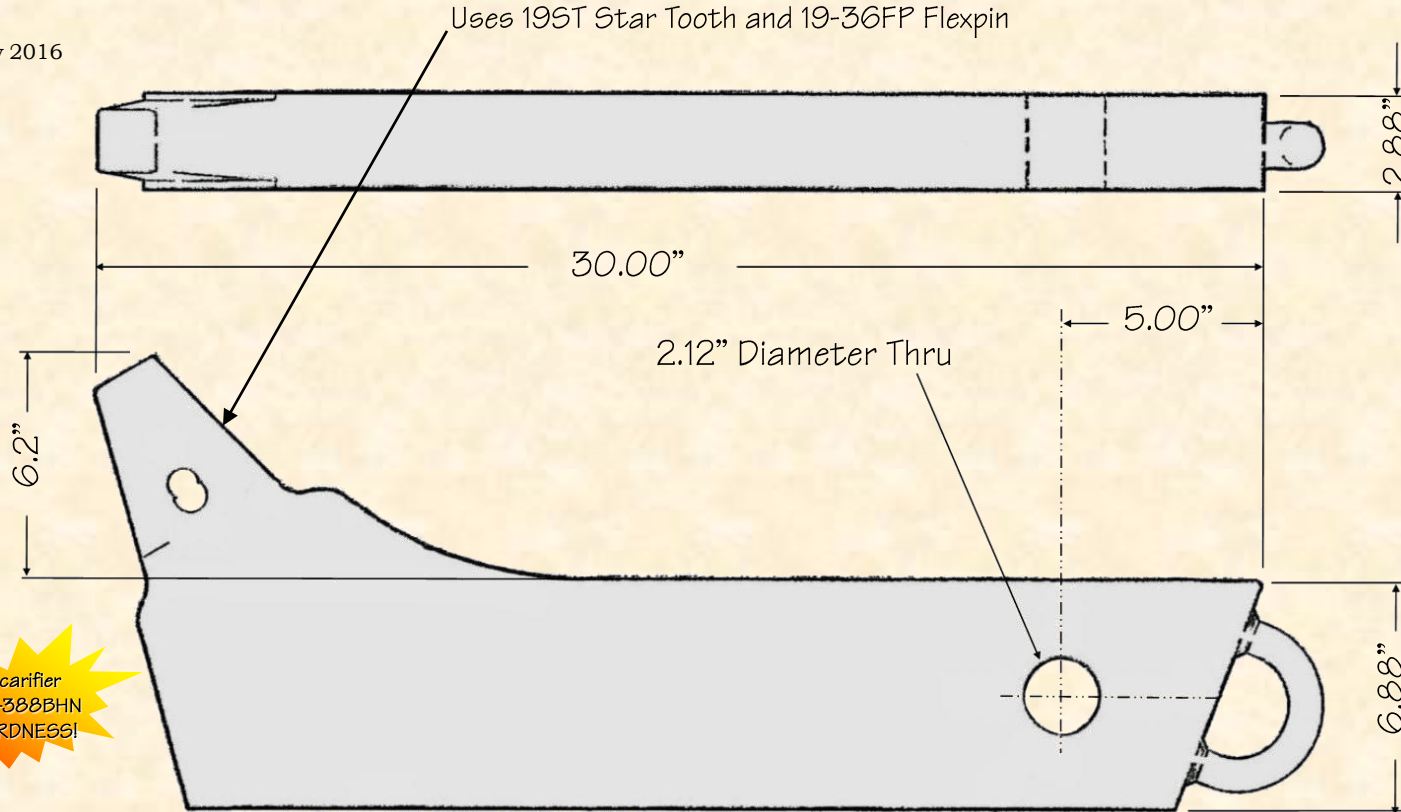

© H&L Tooth Company 2016

H&L's Style R-515-A-19 Rippers are produced from Chrom-Moly-Nickel grade alloy steels to enhance shank **DURABILITY** and **TOUGHNESS!**



ORIGINAL PRODUCT

H&L® TOOTH COMPANY

Factory Direct Made in Tulsa, Oklahoma

R-515-A-19

Ripper Shank

170.0#/177.2kgs.

H&L Tooth Company History since 1931:

This H&L's style R-515-A-19 ripping shank is designed to replace Caterpillar part numbers 8J-3215 and 9J3139, fitting Models D-5, D-6 and 977.

H&L ripper shank uses the H&L 19-Series tooth system. Original ripper shank was engineered and introduced by the H&L Tooth Company in 1975.

H&L products meet or exceeds all OEM standards.