

R128,2017



**QUALITY**  
since 1931

H&L Style RV-840086-YC-38 Rippers are produced from Chrom-Moly-Nickel grade alloy steels to enhance shank **DURABILITY** and **TOUGHNESS!**

© H&L Tooth Company 2017

Uses 38ST-4R Tooth and 38FP Flexpin  
RX-1863 Wear Plate and two RX-1900FP Flexpins

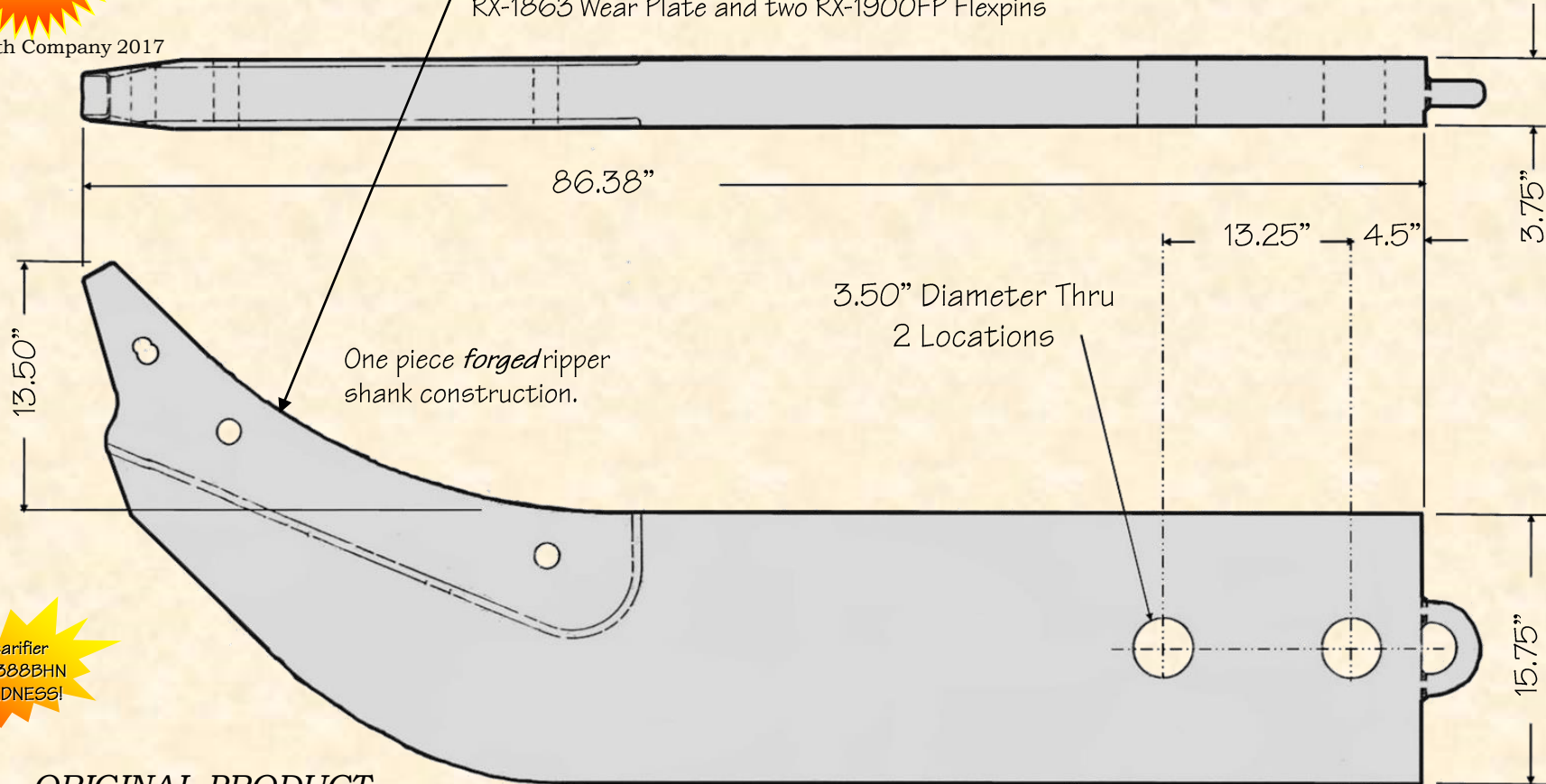

Scarifier  
321-388BHN  
HARDNESS!

ORIGINAL PRODUCT

**H&L® TOOTH COMPANY**

Factory Direct Made in Tulsa, Oklahoma

**RV-840086-YC-38**

Ripper Shank  
1539.24#/1698.20kgs.

*H&L Tooth Company History since 1931:*

*This H&L's style RV-840086-YC-38 Uniforged ripping shank is a replacement for Komatsu's Model D-355, part number 195-79-31140. This shank uses the H&L 38-Series tooth system. Ripper shank was engineered and introduced by the H&L Tooth Company in 1983.*

*H&L products meet or exceeds all OEM standards.*