

R138,2017



QUALITY
since 1931

© H&L Tooth Company 2017

H&L's Style R-517-YS-36 Rippers are produced from Chrom-Moly-Nickel grade alloy steels to enhance shank **DURABILITY** and **TOUGHNESS!**

Uses 36ST-4R Tooth and 19-36FP Flexpin
RX-2017 Wear Plate and two RX-1926FP Flexpins

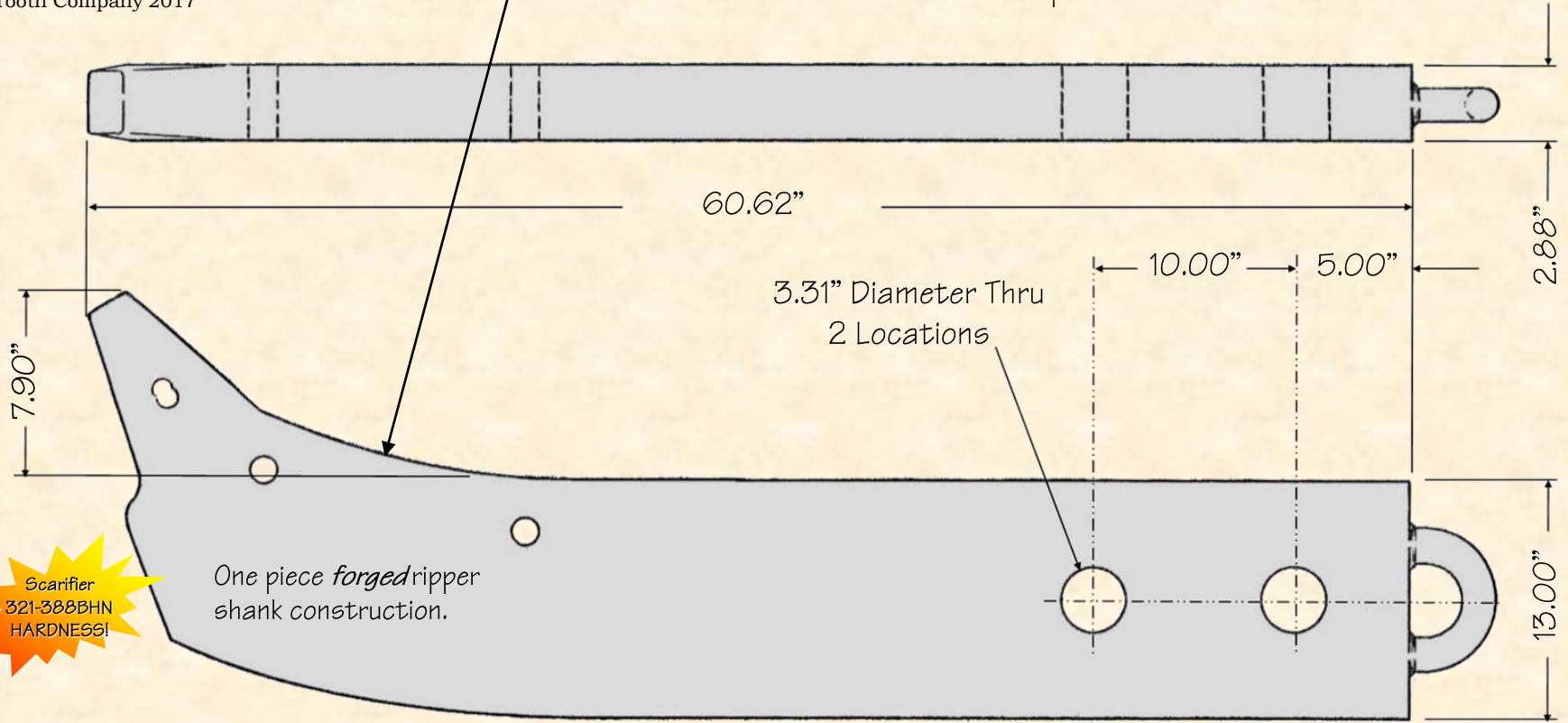

ORIGINAL PRODUCT

H&L® TOOTH COMPANY

Factory Direct Made in Tulsa, Oklahoma

R-517-YS-36

Ripper Shank

625.0#/283.50kgs.

H&L Tooth Company History since 1931:

This H&L's style R-517-YS-36 Uniforged ripping shank is a replacement for International-Harvester's Model TD 25C, part number 705952 C1 and assembly number 705950 C91. This shank uses the H&L 36-Series tooth system. Ripper shank was engineered and introduced by the H&L Tooth Company in 1977. Replaces shank OEM #R-476-AYS-36 with different Wear Plate design.

H&L products meet or exceeds all OEM standards.