

T353.2017



H&L's D-862-2A Adapters are produced from aircraft quality Chrom-Moly grade alloy steels to enhance adapter **DURABILITY** and **TOUGHNESS!**

© H&L Tooth Company 2017

Uses H&L 2AH Teeth.

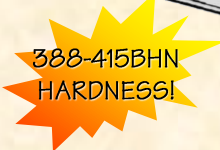
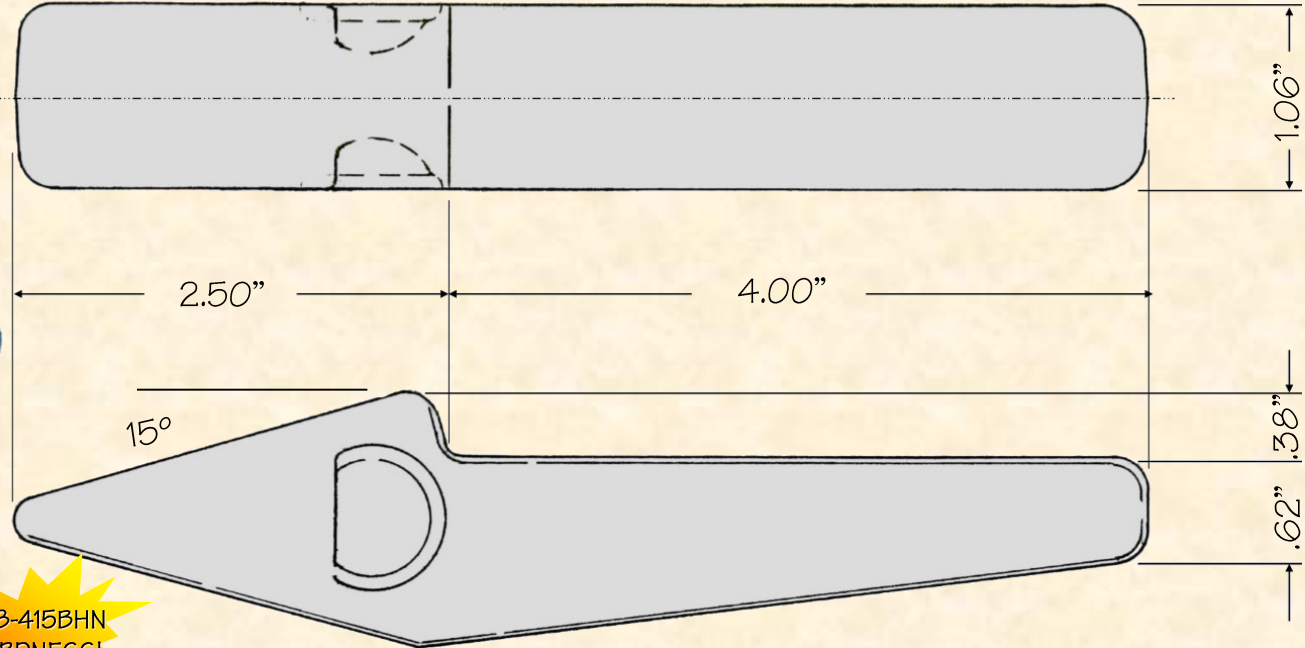

ORIGINAL PRODUCT

H&L® TOOTH COMPANY

Factory Direct Made in Tulsa, Oklahoma

The "OEM" Crimp-On Style WELD-ON ADAPTER design

D-862-2A

Bottom Strap Adapter

1.6#/10.73kgs.

H&L Tooth Company History since 1931:

This Bottom Strap weld-on adapter was first designed introduced by H&L Tooth as an OEM product in 1951 for Buckeye (Garwood), and Cleveland Wheel trenchers.

H&L's D-862-2A weld-on Adapters can be used on Mini-Excavator as a two-part tooth replacement.

Today, H&L continues to produce the "Original" D-862-2A adapter and 2AH teeth. Many OEM's sold this system as their own; Case, Clark, Fiat-Allis, Massey-Ferguson, Melrose and Ford-New Holland. Numbers associated to the D-862-2A are H36657, 6515119, 1S5-8-2A, 73109919, 1752957, 6515119, 270162, 5862-2A.