

R063.2015



H&L's Cat Style HL-6Y-6147 Rippers are produced from Chrom-Moly-Nickel grade alloy steels to enhance shank **DURABILITY** and **TOUGHNESS!**

© H&L Tooth Company 2015

Uses (R500) HL-4T-45025T-4R Tooth with HL-3G-0500 HL-1U-3644 Wear Plate with HL-3G-0500 Pins

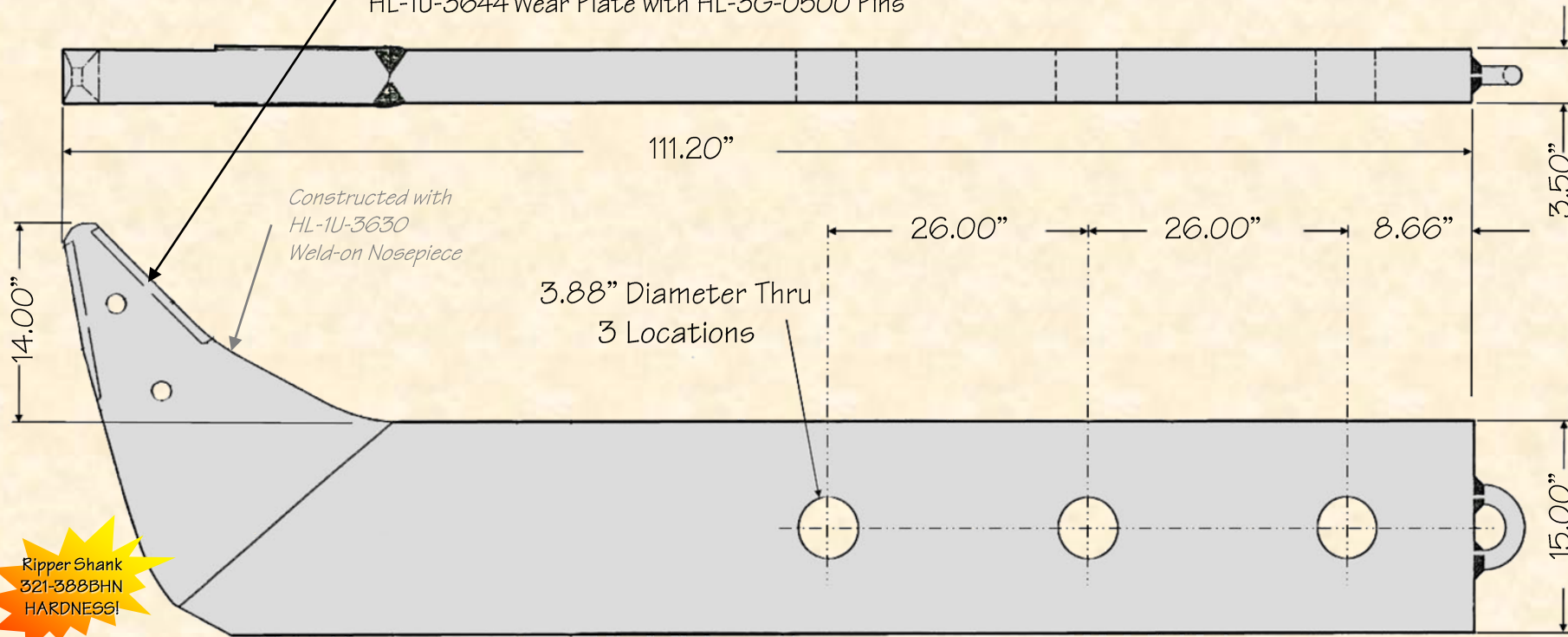

ORIGINAL PRODUCT

H&L® TOOTH COMPANY

Factory Direct Made in Tulsa, Oklahoma

HL-6Y-6147

Ripper Shank

1409.0#/639.12kgs.

H&L Tooth Company History since 1931:

This H&L's Cat style HL-6Y-6147 ripping shank is a replacement for Caterpillar's Model D10N, replaces part number 6Y-6147. This shank uses the H&L's R-500 Series tooth system. Ripper shank was engineered and introduced by the H&L Tooth Company in 1994.

H&L products meet or exceeds all OEM standards.