

R069.2019



H&L's Cat Style HL-8E-5340 Rippers are produced from Chrom-Moly-Nickel grade alloy steels to enhance shank **DURABILITY** and **TOUGHNESS!**

© H&L Tooth Company 2019

Uses (R450) HL-9W-2452ST-4R Tooth with HL-4T-2479 Pin  
HL-6J-8814 Wear Plate with one HL-4T-2479 and one HL-6J-8811 Pins.

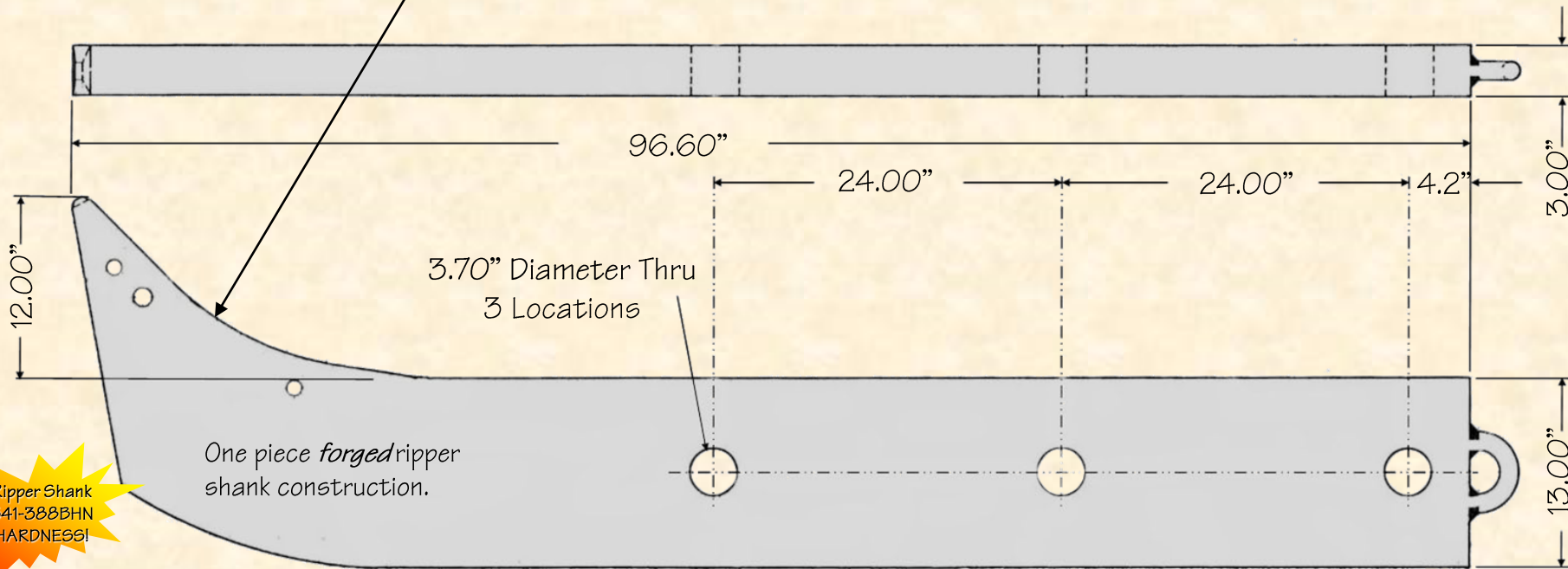

Ripper Shank  
341-388BHN  
HARDNESS!

ORIGINAL PRODUCT

**H&L® TOOTH COMPANY**

Factory Direct Made in Tulsa, Oklahoma

**HL-8E-5340**

Ripper Shank

1120.0#/1508.03kgs.

*H&L Tooth Company History since 1931:*

*This H&L's Cat style HL-8E-5340 ripping shank is a replacement for Caterpillar's Model D8N, D8L and D8R Dozers. This shank uses the H&L's R-450 Series tooth system. Ripper shank was engineered and introduced by the H&L Tooth Company as a forged shank in 1987.*

*H&L products meet or exceeds all OEM standards.*