



H&L Original GET

Ground Engaging Tools for Case Equipment



Our 188,000 square foot manufacturing facility in Tulsa, Oklahoma, H&L's home of **QUALITY FORGED WEAR PARTS.**

All manufactures names, numbers, symbols and descriptions are used for reference purposes only and is not implied that any portion there of, is the product of these manufacturers.



Catalog HL-11-94 updated 176.2015

TOOTH APPLICATION CHART

© H&L Tooth Company 2015

FOR CASE MODELS

Reference CASE form no CP-1593

"Tooth Selection Match the correct tooth option to the job!"

Case Model Number	Original Number	Tooth Part No.	Adapter Part No.	Pin Part No
W11/B	L77908 L-3445-A-230SP	D51750 230SP	B91264 L-3445-A-23	D39094 23DFP
W14B	L123725 L-3445-D-240SP	L55608 240SP	B91266 L-3445-D-24	D39448 24FP
	D50780 L-3445-230SP	D51750 230SP	D49506 L-3445-23	D39094 23DFP
W14B/H/FL	L70481 252-115-02SP	L55468 252SP	B91277 251-115-02	L32090 25-26FP
W18, W20/B	L48497 240-110-08SP	L55608 240SP	B91274 240-110-08	D39448 24FP
W24	L105651 240-112-06SP	L55608 240SP	B91278 240-112-06	D39448 24FP
W24 Military	L112739 L-2021-F-240SP	L55608 240SP	B91271 L-2021-F-24	D39448 24FP
W24B, W26	L110505 252-112-20SP	L55468 252SP	B91273 251-112-20	L32090 25-26FP
W30	L109023 L-4108-BF-240SP	L55608 240SP	B91272 L-4108-BF-24	D39448 24FP
	L117816 252-212-06SP	L55468 252SP	B91258 251-212-06	L32090 25-26FP
	L117817 Corner L-3623-252SP	L55468 252SP	B91259 L-3623-25	L32090 25-26FP
W30 (Prior)	L124971 Corner L-3623-B-252SP	L55468 252SP	B91270 L-3623-B-25	L32090 25-26FP
621	L117816 252-212-06SP	L55468 252SP	B91258 251-212-06	L32090 25-26FP
	R54275 L-3679-A-240SP	L55608 240SP	B91268 L-3679-A-24	D39448 24FP
310, 450	D40449 L-2630-230SP	D51750 230SP	B91263 L-2630-23	D39094 23DFP
350, 450B/C	D50780 L-3445-230SP	D51750 230SP	D49506 L-3445-23	D39094 23DFP
450C, 455C	R52645 L-3445-D-230SP	D51750 230SP	B91265 L-3445-D-23	D39094 23DFP
850, 1150	R35276 Corner L-3679-240SP	L55608 240SP	B91267 L-3679-24	D39448 24FP
850, 1150B/ C/D, 1155D	D49545 252-110-06SP	L55468 252SP	D49940 251-110-06	L32090 25-26FP
850C, 855C	R33528 240-110-13SP	L55608 240SP	R33529 240-110-13	D39448 24FP

WHEEL LOADERS

CRAWLERS

TOOTH APPLICATION CHART

© H&L Tooth Company 2015

FOR CASE MODELS

Reference CASE form no CP-1593

Case Model Number	Original Number	Tooth Part No.	Adapter Part No.	Pin Part No
850D, 855D	R54275 L-3679-A-240SP	L55608 240SP	B91268 L-3679-A-24	D39448 24FP
1150	R51172 L-3637-A-252SP	L55468 252SP	B91276 L-3637-A-25	L32090 25-26FP
1150	R51173 Corner L-3637-252SP	L55468 252SP	B91275 L-3637-25	L32090 25-26FP
1150E, 1155E	R54193 L-3679-A-252SP	L55468 252SP	B91276 L-3679-A-25	L32090 25-26FP
1150E, 1155E	R54194 Corner L-3679-252SP	L55468 252SP	B91269 L-3679-25	L32090 25-26FP
1450	R35260 252-112-15SP	L55468 252SP	R35259 251-112-15	L32090 25-26FP
1450B, 1455B	R51174 L-3638-A-272SP	L51388 272SP	B91261 L-3638-A-27	R29117 20-27FP
1450B, 1455B	R51175 Corner L-3638-272SP	L51388 272SP	B91260 L-3638-27	R29117 20-27FP
480, 580	Not Serviced D-834-3CH	D27748 3CH	D26368 D-834-3C	Crimp on
580CK, 680	L43266 2740-W-230SP	D51750 230SP	B91262 2740-W-23	D39094 23DFP
580K	D41659 D-834-Y-230SP	D51750 230SP	B91340 D-834-Y-23	D39094 23DFP
580K	D139849 2740-ZW-230SP	D51750 230SP	D48212 2740-ZW-23	D39094 23DFP
680	D140481 2740-AEW-252SP	L55468 252SP	B91258 2740-AEW-25	L32090 25-26FP
780CK	L43255 2740-AW-252SP	L55468 252SP	L43254 2740-AW-25	L32090 25-26FP
880	L43266 2740-W-230SP	D51750 230SP	B91262 2740-W-23	D39094 23DFP
880/R	L43255 2740-AW-252SP	L55468 252SP	L43254 2740-AW-25	L32090 25-26FP
1835, 1845	T40472 L-2520-W-2AH	T41166 2AH	T41165 L-2520-W-2A	Crimp on
1835, 1845	D127919 L-2520-BW-2AH	T41166 2AH	D127918 L-2520-BW-2A	Crimp on

CRAWLERS

LOADER/BACKHOE

EXCAVATORS

UNLOADER

Fabricated Teeth

0, 00, 2AH, 3CH Series

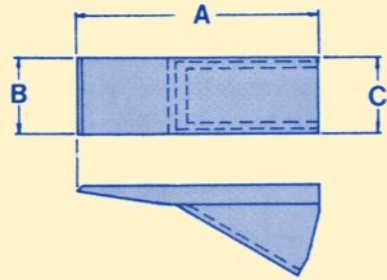

Fabricated Teeth

Case Number	H&L Number	Tooth Styles	A	B	C
H34546	0SP	Sharp	2.56"	1.12"	1.12"
ZJZ00	00SP	Sharp	3.36"	1.44"	1.44"
T41166	2AH	Heavy	4.12"	1.62"	1.62"
D27748 D58593	3CH	Heavy	5.00"	2.25"	2.25"
ZJZ3CW	3CHW	Flared	5.00"	4.50"	2.25"

0, 00, 2AH, 3CH Series Adapters

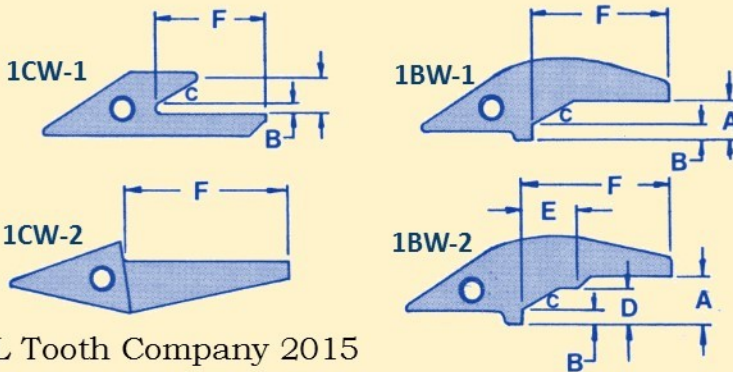

© H&L Tooth Company 2015

Case Number	H&L Number	Styles	A	B	C	D	E	F
D127918	L-2520-BW-2A	1BW-1	0.81"	0.19"	22	-	-	3.75"
	D-838-0	1CW-2	-	-	-	-	-	2.25"
H36657	D-862-2A	1CW-2	-	-	-	-	-	4.00"
	2898-W-00	1CW-1	0.50"	0.19"	20	-	-	3.00"
H61283 7704801	D-835-2A	1CW-1	1.00"	0.38"	30	-	-	4.06"
D26368 7704802	D-834-3C	1CW-1	1.00"	0.38"	30	-	-	4.09"
T41165	L-2520-W-2A	1BW-2	0.69"	0.12"	22	0.50"	1.50"	3.75"



Fabricated, Cast and Forged Teeth

23 and 230 Series

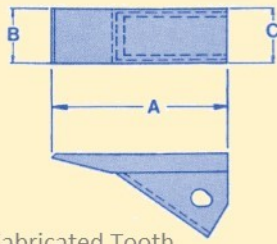

Fabricated Tooth

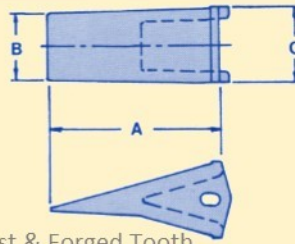

Cast & Forged Tooth

Fabricated Teeth

Case Number	H&L Number	Tooth Styles	A	B	C
D39093 D58590	23SP	Sharp	5.06"	2.25"	2.25"
ZJZ23W	23HW	Flared	5.00"	4.50"	2.25"

Cast Value Teeth

Case Number	H&L Number	Tooth Styles	A	B	C
442677A1	230CSP	Sharp	6.00"	2.25"	2.25"
B96108	230CST	Star	6.25"	0.38"	2.25"
251474	230THD	Single Tiger	6.25"	0.25"	2.25"
D140561	230TW	Twin Tiger	6.50"	2.88"	2.25"
Optional	230TF	Fangs	6.12"	1.75"	3.00"
Optional	230TR3	Triple Tiger	7.00"	4.00"	2.50"
Optional	230SP-5	Lip Saver	6.50"	1.50"	4.50"
Optional	230HD-5	Lip Saver	6.50"	1.50"	4.50"
Optional	230T9-5	Lip Saver	6.50"	0.25"	4.50"
Optional	230TT7-5	Lip Saver	6.50"	3.25"	4.50"
Optional	230CF	Flared	5.25"	4.50"	2.25"
Optional	230CHF	Flared	6.50"	4.50"	2.38"
Optional	230CHFC	Corner			

Unforged Teeth

Case Number	H&L Number	Tooth Styles	A	B	C
D51750 442689A1	230SP	Sharp	6.12"	2.12"	2.25"
D79100 87407887	230ST	Star	6.25"	0.25"	2.38"
D80119	230T9	Single Tiger	6.50"	0.25"	2.38"
D156045	230TT7	Twin Tiger	6.75"	3.00"	2.38"
Optional	230CLAW	Fangs	6.25"	1.50"	2.38"
Optional	230TTCLAW	Fangs Twin	6.50"	3.25"	2.38"
Optional	230CTT	Twin Tiger	6.25"	2.75"	2.38"
Optional	230F	Flared	6.50"	4.50"	2.38"



© H&L Tooth Company 2015



Weld on and Bolt on Adapters

23 and 230 Series



Weld on Series Adapters

© H&L Too5th Company 2015

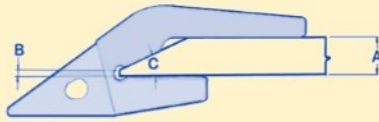

1W STYLE

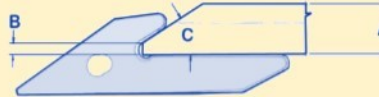

1CW STYLE

Case Number	H&L Number	Styles	A	B	C
D48035	3473-W-23	1W	1.06"	0.19"	23
B91262 7703990	2740-W-23	1W	1.06"	0.19"	23
B900568 7704302	2740-AW-23	1W	0.91"	0.19"	23
B900567	2740-MW-23	1W	0.91"	0.25"	23
D48212 D91886	2740-ZW-23	1W	1.06"	0.19"	23
D138157	2740-AFW-23	1W-AF	1.06"	0.19"	23
ZJZ83423	D-834-23	1CW	1.00"	0.19"	30
B91340	D-834-Y-23	1CW	1.00"	0.19"	23



1W Style Adapter



1W-AF Style Adapter



1CW Style Adapter

Bolt on Series Adapters

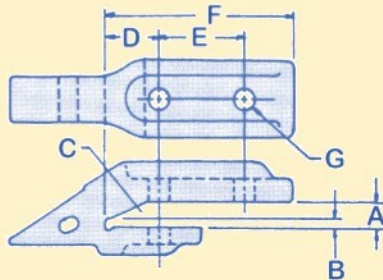

1 Style

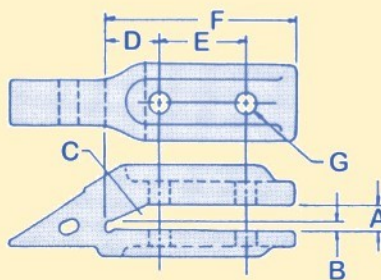

1A Style

Case Number	H&L Number	Styles	A	B	C	D	E	F	G
D49586 7704803	L-3445-23	1	0.81"	0.19"	23	2.25"	3.00"	6.48"	0.69"
B91263	L-2630-23	1A	1.09"	0.12"	23	3.06"	4.25"	8.00"	0.56"
B91264	L-3445-A-23	1	0.69"	0.19"	23	1.75"	3.00"	5.88"	0.69"
B91265	L-3445-D-23	1A	0.81"	0.19"	23	2.25"	3.00"	6.12"	0.69"
L11678	230-110-00	1	1.06"	0.19"	30	2.25"	3.25"	6.50"	0.69"
L16667	230-107-00	1	0.94"	0.19"	30	2.25"	3.25"	6.50"	0.69"
L302016	230-112-06	1	1.19"	0.44"	30	2.38"	2.38"	5.75"	0.56"



1 Style Bolt on Adapter



1A Style Bolt on Adapter

Teeth, Weld on and Bolt on Adapters

24 and 240 Series



© H&L Tooth Company 2015

Fabricated, Cast and Forged Teeth

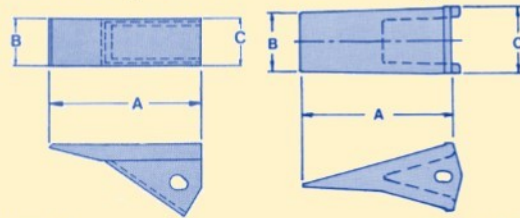

Fabricated

Cast & Forged Tooth

Case Number	H&L Number	Tooth Styles	A	B	C
D39039 7703113	24SP	Sharp	6.50"	2.25"	2.25"
L55608 87411607	240SP	Sharp	7.25"	2.20"	2.20"
R54258	240ST	Star	7.62"	0.19"	2.20"
L55608	240CSP	Sharp	7.25"	2.30"	2.30"
9624498	240CT	Tiger	7.62"	0.25"	2.30"

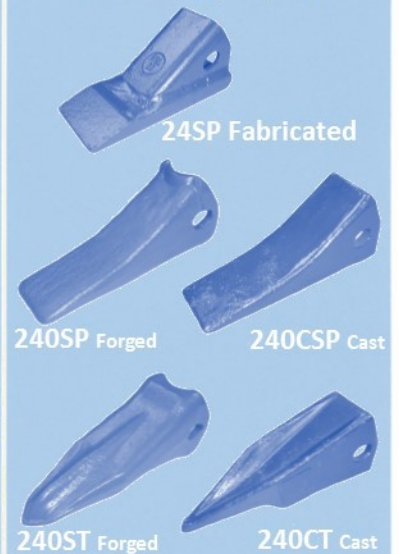

Weld on Series Adapter

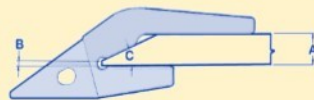

1W STYLE

Case Number	H&L Number	Styles	A	B	C
ZJZ2740KW 7703112	2740-KW-24	1W	1.06"	0.38"	23



1W Style Adapter



1B Style Bolt on Adapter

Bolt on Series Adapters

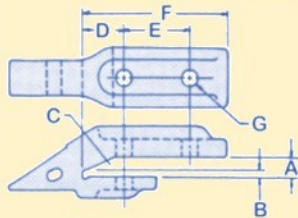

1 Style

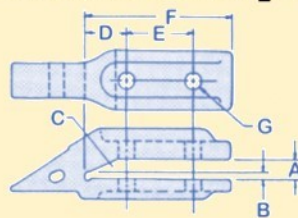

1A Style

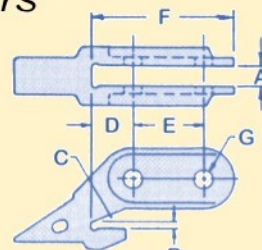

1A-COR Style

Case Number	H&L Number	Styles	A	B	C	D	E	F	G
B91266	L-3445-D-24	1A	0.81"	0.19"	23	2.25"	3.00"	6.12"	0.69"
B91267	L-3679-24	1A-COR	1.06"	0.62"	23	2.75"	3.75"	7.85"	0.81"
B91288	L-3679-A-24	1A	1.06"	0.41"	23	2.75"	3.75"	7.85"	0.81"
B91271	L-2021-F-24	Drott	0.81"	0.28"	25	3.38"	3.00"	7.38"	0.69"
B91274	240-110-08	1	1.06"	0.25"	30	2.50"	3.50"	7.25"	0.69"
B91278	240-112-06	1	1.31"	0.44"	30	2.50"	3.50"	7.25"	0.69"
R33529	240-110-13	1	1.03"	0.44"	24	2.75"	3.75"	7.50"	0.69"
B91272	L-4108-BF-24	1B	1.00"	0.19"	23	2.46"	3.50"	7.00"	0.69"



Drott Style Adapter



1 Style Bolt on Adapter



1A Style Bolt on Adapter



1A-COR Style Bolt on Adapter

Teeth, Weld on and Bolt on Adapters

252 Series



© H&L Tooth Company 2015

Cast and Forged Teeth

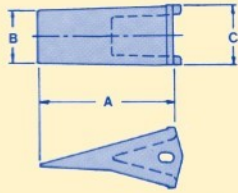

Case Number	H&L Number	Tooth Styles	A	B	C
D55468	252SP	Sharp	7.88"	2.75"	2.75"
D59702	252ST	Star	8.38"	0.38"	2.75"
442686A1	252CSP	Sharp	7.75"	2.75"	2.75"
Optional	252CT	Tiger	7.75"	0.38"	2.75"



252SP Forged 252CSP Cast

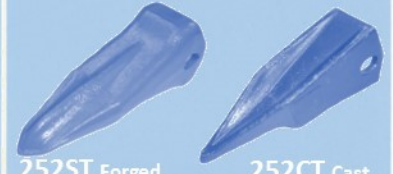

252ST Forged 252CT Cast

Weld on Series Adapter

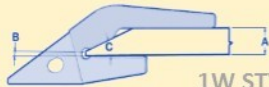

1W STYLE

Case Number	H&L Number	Styles	A	B	C
L43255 7703116	2740-AW-25	1W	1.31"	0.50"	23
D129197 444043A1	2740-AEW-25	1W	1.34"	0.50"	23



1W Style Adapter

Bolt on Series Adapters

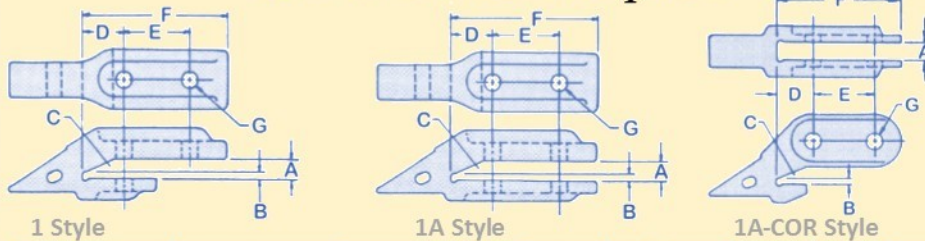

1 Style

1A Style

1A-COR Style

Case Number	H&L Number	Styles	A	B	C	D	E	F	G
B91258	251-212-06	1A	1.31"	0.50"	28	2.50"	3.50"	7.25"	0.81"
B91259	L-3623-25	1A-COR	1.28"	0.62"	30	2.50"	3.50"	7.00"	0.81"
B91269	L-3679-25	1A-COR	1.06"	0.62"	23	2.85"	3.75"	7.85"	1.06"
B91270	L-3623-B-25	1A-COR	1.28"	0.62"	30	2.50"	3.50"	7.00"	0.69"
B91273	251-112-20	1	1.31"	0.50"	28	2.50"	3.50"	7.50"	0.69"
B91275	L-3637-25	1A-COR	1.06"	0.62"	23	2.85"	3.75"	7.85"	0.81"
B91276	L-3637-A-25	1A	1.06"	0.41"	23	2.75"	3.75"	7.75"	0.81"
B91277	251-115-02	1	1.31"	0.50"	23	3.00"	3.50"	8.38"	0.81"
B91279	L-3679-A-25	1A	1.06"	0.41"	23	2.75"	3.00"	7.75"	1.06"
D49940	251-110-06	1	1.03"	0.44"	24	3.25"	3.75"	8.50"	0.69"
R35259	251-112-15	1	1.31"	0.44"	24	3.00"	4.25"	8.25"	0.81"



1 Style Bolt on Adapter



1A Style Bolt on Adapter



1A-COR Style Bolt on Adapter

Teeth, Scarifiers and Small Rippers

1 3/4, 22, 24 and 25 Series



Fabricated and Forged Teeth

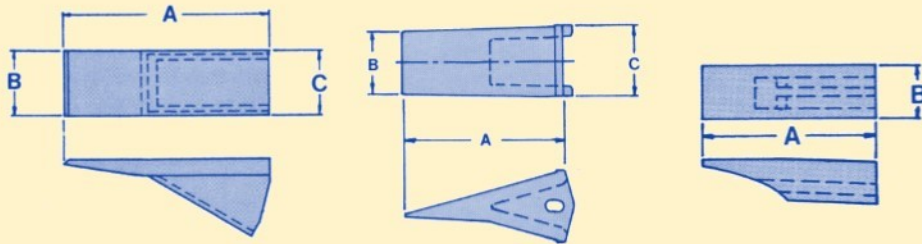

Fabricated Style

Forged Style

Slip on Style

Case Number	H&L Number	Tooth Styles	A	B	C
K3871	1 3/4SP	Sharp	5.19"	1.25"	1.25"
D83306	22SP	Sharp	7.12"	1.81"	1.81"
L55608	240SP	Sharp	7.25"	2.20"	2.20"
R54258	240ST	Star	7.62"	0.19"	2.20"
D55468	252SP	Sharp	7.88"	2.75"	2.75"
D59702	252ST	Star	8.38"	0.38"	2.75"
R33815	HL-6Y-5230	Sharp	7.18"	1.81"	-

© H&L Tooth Company 2015

Scarifiers and Small Rippers

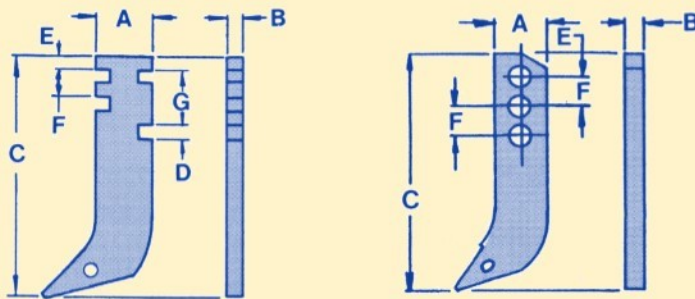

Scarifier Style

Small Ripper Style

Case Number	H&L Number	Styles	A	B	C	D	E	F	G
K3872	G-959-3/4	Scarifier	2.50"	0.75"	21.88"	0.62"	0.50"	4.00"	7.00"
R18255	G-616-24	Ripper	4.50"	1.50"	28.50"	-	1.50"	-	-
R46112	R-506-24	Ripper	5.50"	1.50"	25.67"	-	5.31"	-	-
R48569	R-507-C-25	Ripper	7.00"	2.00"	32.50"	-	5.00"	3.50"	-
T40754	G-163-HW-3/4	Scarifier	2.50"	0.75"	15.50"	0.53"	0.53"	2.50"	-
T42055	G-163-CD-3/4	Scarifier	2.50"	0.75"	15.50"	0.50"	0.53"	2.50"	3.00"
	R-560-24	Ripper	4.00"	1.50"	23.00"	-	2.00"	-	-
ZJZ5940	HL-5-0940	Scarifier	3.00"	1.00"	17.75"	0.93"	0.67"	1.58"	1.58"



HL-6Y-5230



Scarifier Style



Small Ripper Style

Case Part Numbers

© H&L Tooth Company 2015



Conversion to H&L Part Numbers

Case Number	H&L Number
251474	230THD
7703112	2740-KW-24
7703113	24SP
7703116	2740-AW-25
7703990	2740-W-23
7704302	2740-AW-23
7704801	D-835-2A
7704802	D-834-3C
7704803	L-3445-23
9624498	240CT
88411607	240SP
122236A1	R-506-24
122237A1	R-507-C-25
221535A1	R-560-24
245466A1	23FP
442677A1	230CSP
442686A1	252CSP
442689A1	230SP
444043A1	2740-AEW-25
B900567	2740-MW-23
B900568	2740-AW-23
B91085	K-975
B91258	251-212-06
B91259	L-3623-25
B91260	L-3638-B-27
B91261	L-3638-A-27
B91262	2740-W-23
B91263	L-2630-23
B91264	L-3445-A-23
B91265	L-3445-D-23
B91266	L-3445-D-24
B91267	L-3679-24
B91268	L-3679-A-24
B91269	L-3679-25
B91270	L-3623-B-25
B91271	L-2021-F-24
B91272	L-4108-BF-23
B91273	251-112-20
B91274	240-110-08

Case Number	H&L Number
B91275	L-3637-25
B91276	L-3637-A-25
B91277	251-115-02
B91278	240-112-06
B91279	L-3679-A-25
B91288	L-3679-A-24
B91340	D-834-Y-3C
B96108	230ST
D127918	L-2520-BW-2A
D129197	2740-AEW-25
D134686	23RFP
D136045	230TT7
D138157	2740-AFW-23
D138157	2740-AFW-23
D140561	230CTT
D156045	230CTT
D156045	230TT7
D26368	D-834-3C
D27748	3CH
D36720	3CHLR
D39039	24SP
D39090	24SP
D39093	23SP
D39094	23FP
D39448	24FP
D40445	L-2628-24
D40472	L-2520-W-2A
D41656	D-834-23
D43417	22FP
D44193	23LR
D48035	2740-AW-23
D48212	2740-ZW-23
D49586	L-3445-23
D49940	251-110-06
D51570	230SP
D54258	240ST
D55468	252SP
D58576	3CH
D58590	23SP

Case Number	H&L Number
D58593	3CH
D59702	252ST
D79100	230ST
D80119	230T9
D83306	22SP
D91886	2740-ZW-23
H34546	0SP
H36657	D-862-2A
H61283	D-835-2A
K3871	1 3/4SP
K3872	G-959-3/4
L11678	230-110-00
L124971	L-3623-B-25
L129197	2740-AEW-25
L16667	230-107-00
L302016	230-112-06
L32090	25-26FP
L43254	2740-AW-25
L43255	2740-AW-25
L43266	2740-AW-23
L55608	240SP
R18255	G-616-24
R29115	271-112-01
R29117	20-27FP
R33529	240-110-13
R33815	HL-6Y-5230
R35259	251-112-15
R46112	R-506-24
R48569	R-507-C-25
R500567	2740-MW-23
R500568	2740-AW-23
R51388	272SP
R54257	272ST
R54258	240ST
T40754	G-163-HW-3/4
T41165	L-2520-W-2A
T41166	2AH
T42055	G-163-CD-3/4
ZJZ23W	23HW

Flexpin® and Remover Tools

23 Series Flexpin® and B23HL Tool

23FP Flexpin®, Case #245466A1 & D39094

The Original Flexpin design produced for all 23 and 230 Series Tooth Systems.



Original Length

230FP Flexpin®, Replaces Case #245466A1

The Delta Wing Flexpin Longer design is ideal as a Fangs Replacement



Longer Length

23FP Flexpin®, Replaces Case Flexpins

The Double Locking Flexpin has been design to better lock for loose assemblies.



Double Locking Lugs

© H&L Tooth Company 2015



Flexpin® is the registered Trademark of the H&L® Tooth Company



H&L® NEW Pin Caddy™

B23HL1 Patented Tool for ALL 230 Series Teeth

Pin Caddy™ Holds a Complete Set of Flexpins

Pin Caddy™

Comes with five **FREE** Flexpins

Your **Choice** of Flexpin® Styles!



**REMOVE IT
FASTER!**



Flexpin®
Removal



Flexpin®
Installation

PATENTED! No Other Pin Tool Compares
Work Safely! As always, safety glasses and gloves are recommended.

Flexpins®

24, 25 and Other Series

24FP Flexpin®, Case Number D39448

The Original Flexpin Design produced for all 24 and 240 Series Tooth Systems.



25-26 FP Flexpin®, Case Number L32090

The Original Flexpin Design produced for all 25 and 252 Series Tooth Systems.



20-27FP Flexpin®, Case Number R29117

The Original Flexpin Design produced for all 20 and 272 Series Tooth Systems.

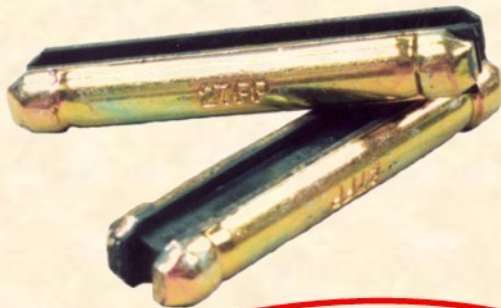

H&L FLEXPIN POINT CONNECTION

An animated rubber insert illustrates the lifelike action of the H&L Flexpin inside the connection.

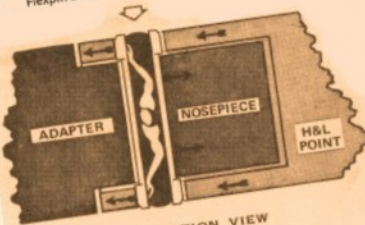

CROSS-SECTION VIEW



The H&L Flexpin consists of two half-round lengths of steel with a section of live rubber vulcanized between to form an oval shaped pin. In use within the nosepiece of the adapter and the pin holes of the Point, the compressed rubber forces the Flexpin half-round sections in opposite direction. (Refer to illustration at left.) One half-round section bears on the nosepiece and the other bears at each side of the Point to hold it securely on the adapter. The design of the Flexpin serves to lock it in place.

U.S. PATENTS: 2568075, 2716822, 2669153, 2914868, 2807105, 2632261, 2762139, 2798403, 2837844, 3020655, 3016727
CANADIAN PATENTS: 490650-1953, 490651-1953, 500919-1954, 577430-1959, 585026-1959, 5973307-1960, 617300-1962
OTHER PATENTS PENDING INCLUDING FOREIGN.



Flexpin® is the registered Trademark of the H&L® Tooth Company

Introduction and General Information Sheet. H&L Classic Catalog of 50 years ago.

