



www.hltooth.com

Tooth Company Ground Engaging Tools

Wear Parts for:

•H&L® MINING PRODUCTS

**H&L® VP
Style
Teeth**



**H&L®
Wedge
Key and
Clamp
Assembly**



**Wear
Shrouds for
Cat BE Style 7495**

**Quality
GET since
1931**

**H&L® Rope Shovel Whisler 10 and 12
Series Base Adapters**



**Wear
Shrouds for P&H
Komatsu Style 4100**

**Komatsu®
Style
Ripper
Shanks**



**Custom Made
Weld-On
Style
Adapters**



**OEM style lip
gauges for
repairing
dipper
shovels**



Caterpillar® Style Ripper Shanks



1-800-HL TOOTH

Home of the H&L Tooth Company, Tulsa Oklahoma



200,000 square foot
manufacturing facility
for **QUALITY FORGED**
WEAR PARTS

1-800-HL TOOTH (1-800-458-6684) • Visit us at www.hltooth.com

©H&L Tooth Company 2018

Page #

product index

3

H&L® 546, 543, 541 and 646 Mining teeth with **Flexhol®** and hammerless attaching Hardware.

4

H&L® Mining 512-TWC-546 Base Adapters for Rope Shovel Equipment utilizing Whisler 12 series connections with dipper lip dimensions.

5

H&L® Mining 510-TWC-546 Base Adapters for Rope Shovel Equipment utilizing Whisler 10 series connections with dipper lip dimensions.

6

H&L® Mining 508-TWC-546 Base Adapters for Rope Shovel Equipment utilizing Whisler 8 series connections with dipper lip dimensions.

7

H&L® Mining 506-TWC-543 and 506-TWC-541 Base Adapters for Rope Shovel Equipment utilizing Whisler 6 series connections with dipper lip dimensions.

8

Details of **H&L®** patented **Flexhol®** tooth attaching systems, 546, 543 and 541 Series. Details of Hammerless 646PN8 tooth-to-base connection.

9

Details of **H&L® Wedge Key and Clamp** connection for all Whisler 6-8-10 and 12 field connections.

10

H&L® Wear Shrouds for older **P&H®** 4100 Rope Shovels utilizing the Whisler 12 Base Adapter connection.

11

H&L® Wear Shrouds for **Caterpillar®** 7495 (*formally Bucyrus® 495*) Rope Shovels utilizing the Whisler 12 Base Adapter connection.

12

H&L® Caterpillar® style R450, R500 AND R550 **FORGED Ripper Teeth**. A complete *Ripper Shank LISTING* for **D 8, D 9 and D10 Caterpillar® Dozers**.

13

H&L® complete *Ripper Shank LISTING* for **D 8, D 9 and D10 Caterpillar® Dozers**. **H&L® Caterpillar®** style R450, R500 AND R550 **Pin and Retainers**.

14

H&L® Komatsu® style **KR1, KR2 AND KR3 FORGED Ripper Teeth and Pins**. A complete *Ripper Shank LISTING* for **Komatsu® Dozers**.

15

Universal Gauging number X-2562-N for **WH-4, WH-6, WH-8, WH-10 and WH-12** key and clamp hole adjustable gauge.

16

OEM style lip gauges for **WH-6, WH-8, WH-10 and WH-12**. Perfect for field checking and grind repairing of dipper lips.

17

H&L® WELD-ON adapter systems for all hydraulic large shovels, backhoes and front end loaders.

18

H&L® WELD-ON adapter systems for all hydraulic Large Shovels.

19

Comments and Notes

H&L® Large Mining Teeth and Pin Products

© H&L Tooth Company 2018

Mining "Flexhol" Style Teeth and Attaching Hardware

546 SERIES



546RXH
205.0#

Rock Extra Heavy



546SP
185.0#

Sharp Penetration

646 SERIES



Hammerless
646RXH
205.0#

Rock Extra Heavy

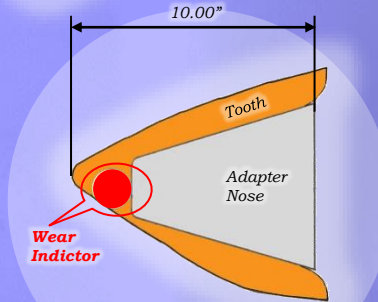

Typical Worn Tooth Profile

Only the 546 and 646 Series has a built in wear indicator. It identifies when the tooth wear length is nearing 10.00".

543 SERIES



543RK
138.0#

Rock Tooth



543SS
125.0#

Short Penetration

541 SERIES



541RK
122.0#

Rock Tooth



541P
105.0#

Penetration Tooth

546Flexhol® System



546PN
Steel Pin



For Details see page 8

546HL
Elastomer
Insert

646PN8 Hammerless Connection



646CP8
Steel Cap

For Details see page 8

646BD8
Steel Body

543Flexhol® System



543PN
Steel Pin



For Details see page 8

543HL
Elastomer
Insert

541Flexhol® System



541PN
Steel Pin



For Details see page 8

541HL
Elastomer
Insert

1-800-HL TOOTH

® is a registered trademark of the respectively named Company.

All manufacturer's names, numbers, symbols and descriptions are used for reference purposes only.

H&L® WH-12 MINING Base Adapter Products

© H&L Tooth Company 2018

“WHISLER 12” Flexhol® or Hammerless Series Base Adapter Series

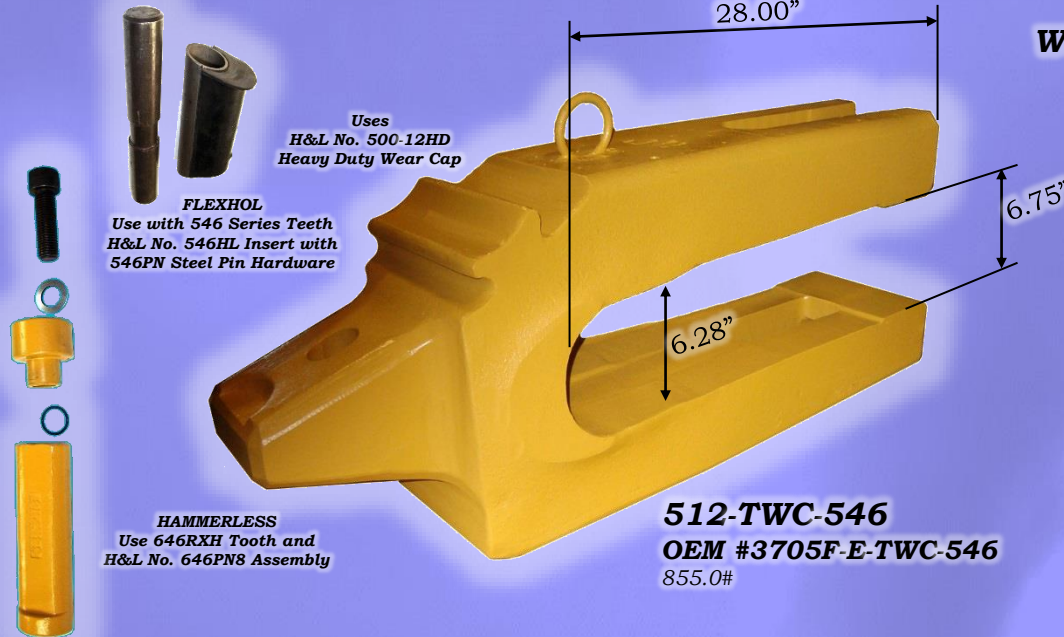

K-512 Series Wedge Keys and Clamp Assembly



For Details see page 9

Key Series	“C” Clamp
K-512-3	K-512-9
K-1307	K-1308
K-1322	K-1323
36.0#	70.0#

512-TWC-546
OEM #3705F-E-TWC-546
855.0#

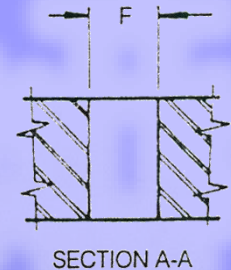
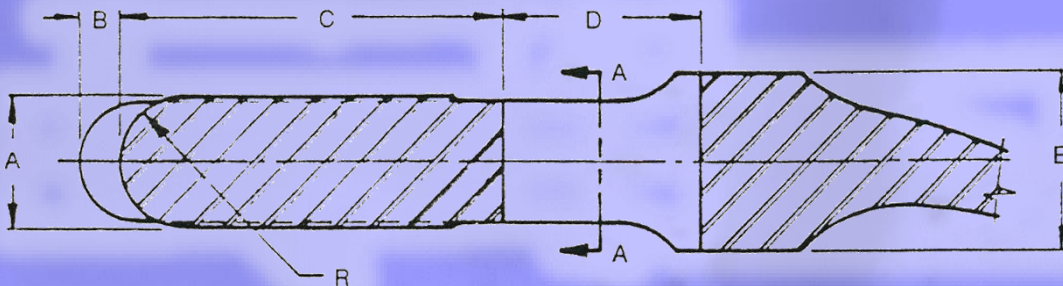

Mfg.	Number	A	B	C	D	E	F	R
Bucyrus-H&L	X-2781-B	6.25”	1.50”	15.88”	8.50”	6.75”	2.88”	3.12”

For inspection and fit gauge availability see page 15

1-800-HL TOOTH

® is a registered trademark of the respectively named Company.

All manufacturer’s names, numbers, symbols and descriptions are used for reference purposes only.

H&L® WH-10 MINING Base Adapter Products

© H&L Tooth Company 2018

“WHISLER 10” Flexhol® or Hammerless Series Base Adapter Series

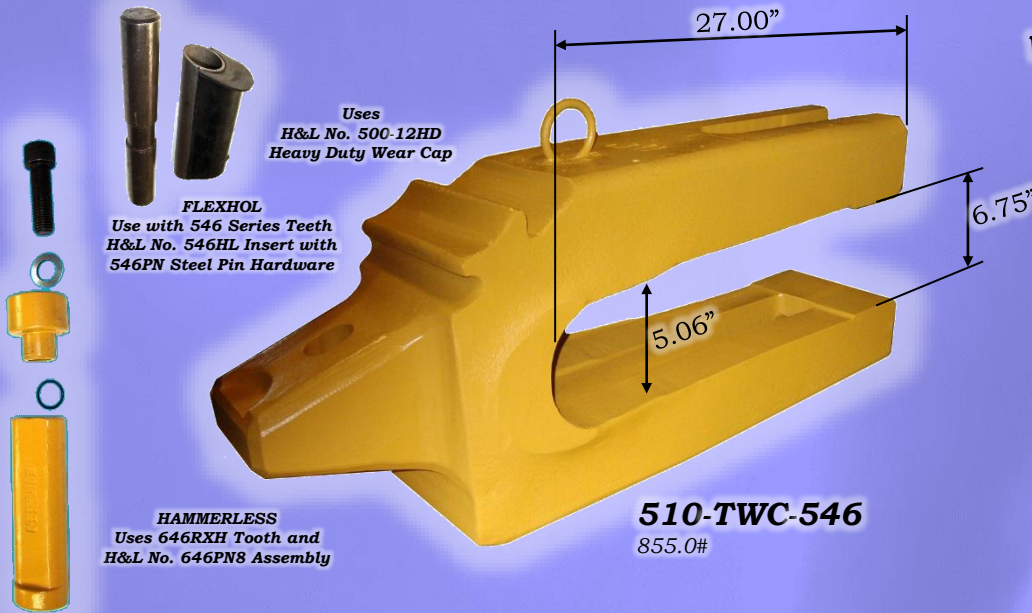

K-510 Series Wedge Keys and Clamp Assembly

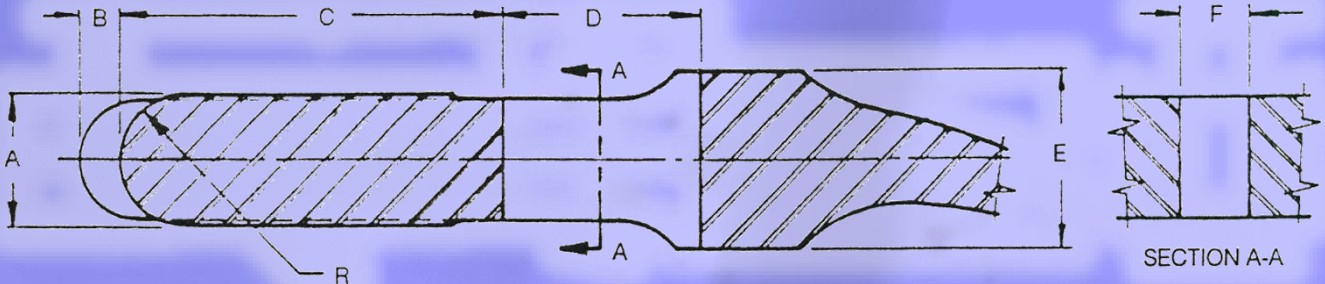

Mfg.	Number	A	B	C	D	E	F	R
Amsco	GA-38867	5.00"	1.50"	15.00"	8.00"	6.75"	2.75"	2.50"
Bucyrus-Erie	889468K1	5.00"	1.50"	15.00"	8.00"	6.75"	2.75"	2.50"
P&H	12-J-704	5.00"	1.50"	15.00"	8.00"	6.75"	2.75"	2.50"

For inspection and fit gauge availability see page 15

1-800-HL TOOTH

®Is a registered trademark of the respectively named Company.
All manufacturer's names, numbers, symbols and descriptions are used for reference purposes only.

H&L® WH-8 MINING Base Adapter Products

© H&L Tooth Company 2018

“WHISLER 8” Flexhol® or Hammerless Series Base Adapter Series

K-508 Series Wedge Keys and Clamp Assembly

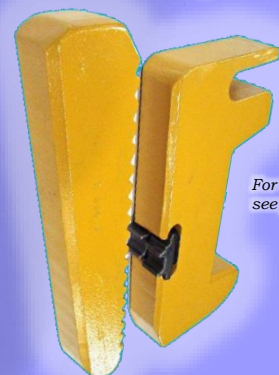

Key Series "C" Clamp
K-508-3 **K-508-9**
K-1297 **K-1298**
 29.0# 55.0#

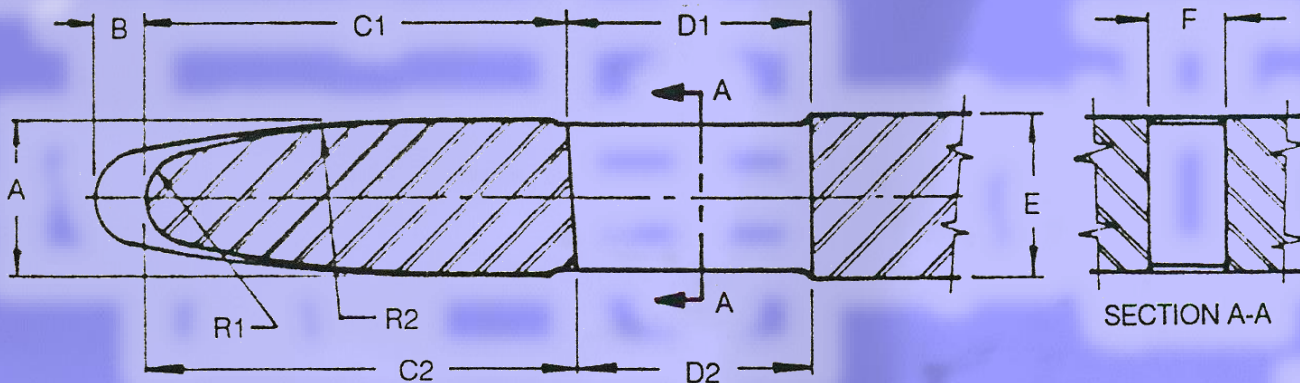

Mfg.	Number	A	B	C1	C2	D1	D2	E	F	R1	R2
Amsco	GA-28992	5.00"	1.62"	12.80"	13.25"	8.20"	7.75"	5.25"	2.50"	1.38"	36.0"
Bucyrus-Erie	870474K1	5.00"	1.62"	12.80"	13.25"	8.20"	7.75"	5.25"	2.50"	1.38"	36.0"
P&H	12-J-668	5.00"	1.62"	12.80"	13.25"	8.20"	7.75"	5.25"	2.50"	1.38"	36.0"
Esco Corp.	CE-14683	5.00"	2.00"	12.81"	13.28"	8.19"	7.72"	5.25"	2.50"	1.38"	36.0"
Marion	813-C-26	5.00"	1.62"	12.80"	13.25"	8.20"	7.75"	5.25"	2.50"	1.38"	36.0"

For inspection and fit gauge availability see page 15

1-800-HL TOOTH

®Is a registered trademark of the respectively named Company.

All manufacturer's names, numbers, symbols and descriptions are used for reference purposes only.

H&L® WH-6 MINING Base Adapter Products

© H&L Tooth Company 2018

“WHISLER 6” Flexhol® Series Base Adapter Series



K-506 Series Wedge Keys and Clamp Assembly



Key Series “C” Clamp
K-506-3 **K-506-9**
K-1299 **K-1300**
 20.0# 29.0#

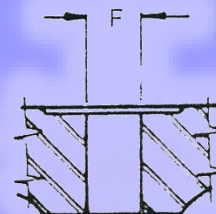
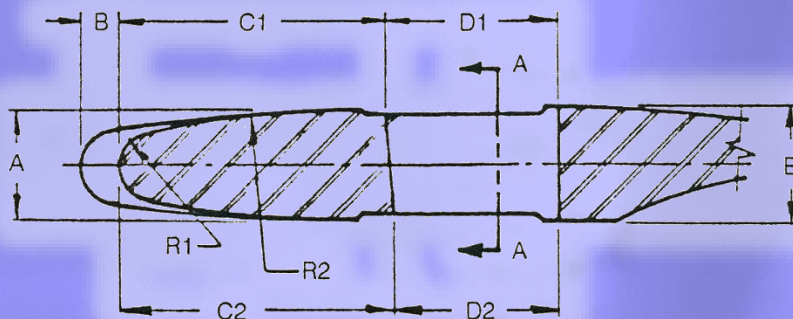

SECTION A-A

Mfg.	Number	A	B	C1	C2	D1	D2	E	F	R1	R2
Amsco	GA-27506	4.25"	1.50"	10.23"	10.62"	6.89"	6.50"	4.50"	2.25"	1.25"	30.0"
Bucyrus-Erie	863825K1	4.25"	1.50"	10.23"	10.62"	6.89"	6.50"	4.50"	2.25"	1.25"	30.0"
P&H	12-J-468	4.25"	1.50"	10.23"	10.62"	6.89"	6.50"	4.50"	2.25"	1.25"	30.0"

For inspection and fit gauge availability see page 15

1-800-HL TOOTH

®Is a registered trademark of the respectively named Company.
 All manufacturer's names, numbers, symbols and descriptions are used for reference purposes only.

H&L® MINING Tooth Attaching Hardware

© H&L Tooth Company 2018

546-543-541 Tooth Attachment Hardware

- **SOLID STEEL** Chrom-Moly Hardened Flexhol® pin!
- Hardened Chrom-Moly Flexhol® **STEEL TUBE** Insert!
- **SHOCK ABSORBING** 80 Shore elastomer!
- Steel Lock guarantees **POSITIVE LOCK!**

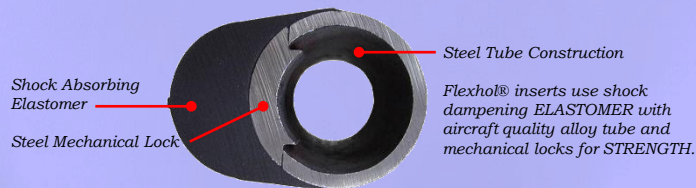

Flexhol® Mechanical Lock Cross Section

546 Flexhol®

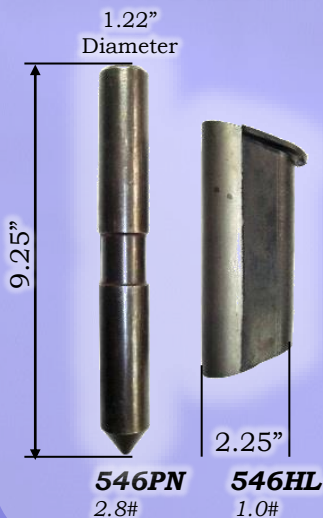

546 Severe Duty Flexhol®



543 Flexhol®

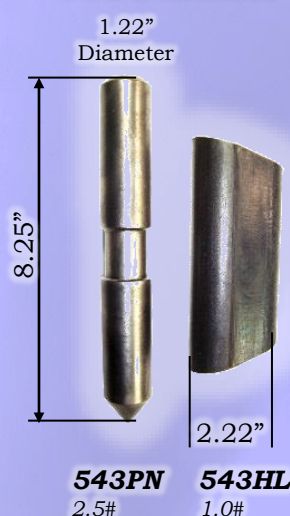

541 Flexhol®

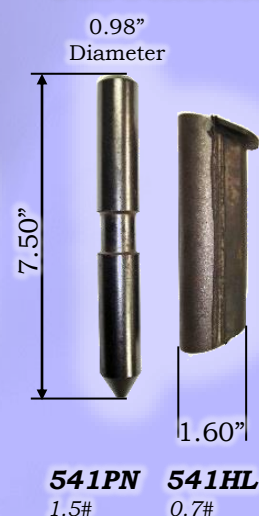

646 Tooth Hammerless Attachment Hardware

646PN8 Assembly

6.7#

646 series hammerless pin assembly is held secure with a self-locking bolt that is easy to install with a standard 3/4" Allen hex Key.

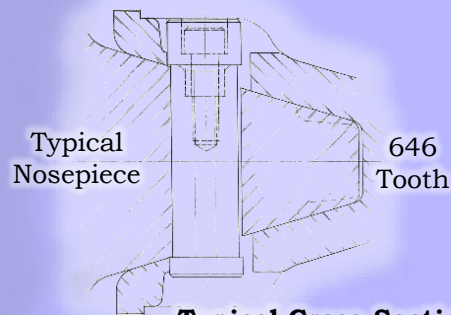

Typical Cross Section

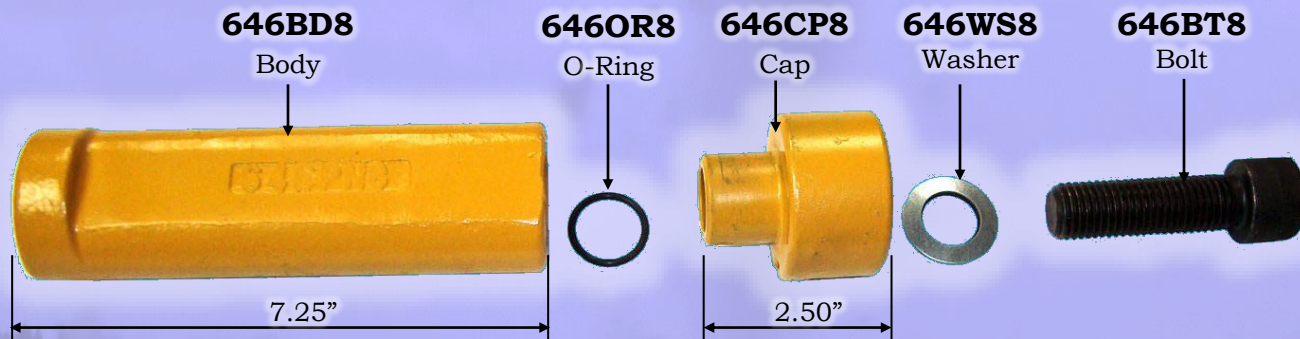

1-800-HL TOOTH

®Is a registered trademark of the respectively named Company.

All manufacturer's names, numbers, symbols and descriptions are used for reference purposes only.

H&L® Base Adapter Attaching Hardware

©H&L Tooth Company 2018

Whisler Style Key & Clamp Hardware

All Clamps use K-1396D Duo-Lok Ratchet Insert.

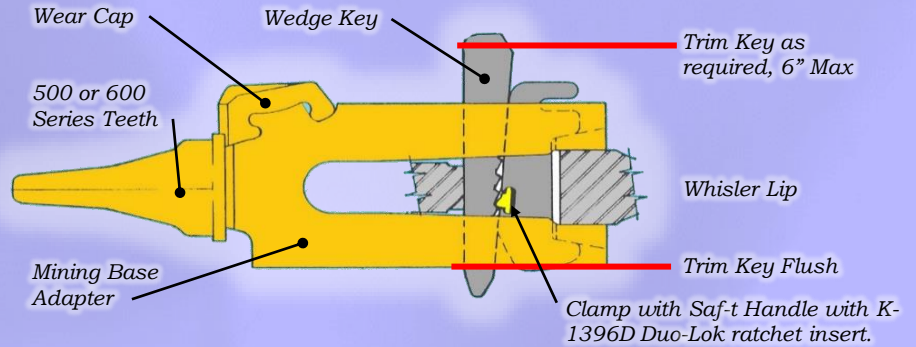

K-512 Series Wedge Keys and Clamp Assembly

Other OEM numbers K-1307 and K-1308



Over and Undersized Keys

Whisler 12 series Wedge Keys are available in oversized keys for worn lips and undersized keys for rebuilt dipper lips.

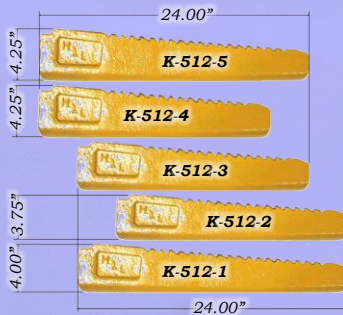

- "5 Key" = 1/4" Oversized, longer length
- "4 Key" = 1/4" Oversized standard length
- "3 Key" = Standard sized and Length
- "2 Key" = 1/4" Undersized standard length
- "1 Key" = 1/4" Undersized, longer length

K-510 Series Wedge Keys and Clamp Assembly

Other OEM numbers K-1294 and K-1295

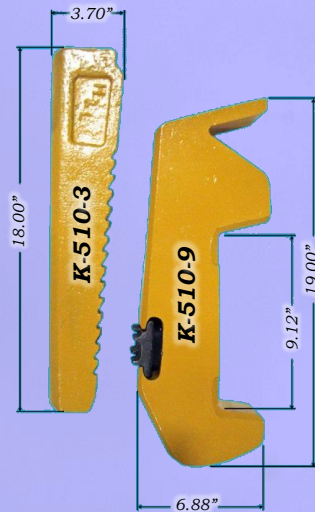

Over and Undersized Keys

Whisler 10 series Wedge Keys are available in oversized keys for worn lips and undersized keys for rebuilt dipper lips.

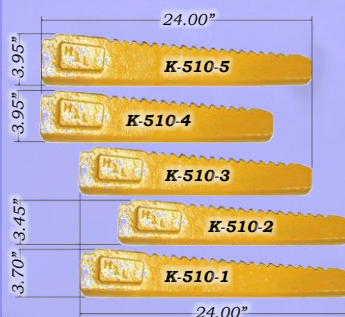

- "5 Key" = 1/4" Oversized, longer length
- "4 Key" = 1/4" Oversized standard length
- "3 Key" = Standard sized and Length
- "2 Key" = 1/4" Undersized standard length
- "1 Key" = 1/4" Undersized, longer length

K-508 Series Wedge Keys and Clamp Assembly

Other OEM numbers K-1297 and K-1298

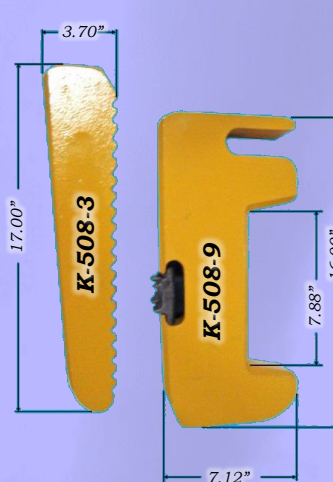

Over and Undersized Keys

Whisler 8 series Wedge Keys are available in oversized keys for worn lips and undersized keys for rebuilt dipper lips.



- "5 Key" = 1/4" Oversized, longer length
- "4 Key" = 1/4" Oversized standard length
- "3 Key" = Standard sized and Length
- "2 Key" = 1/4" Undersized standard length
- "1 Key" = 1/4" Undersized, longer length

K-506 Series Wedge Keys and Clamp Assembly

Other OEM numbers K-1299 and K-1300

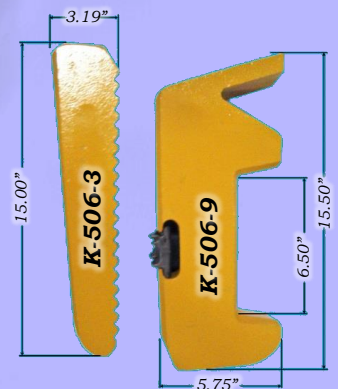

Over and Undersized Keys

Whisler 6 series Wedge Keys are available in oversized keys for worn lips and undersized keys for rebuilt dipper lips.

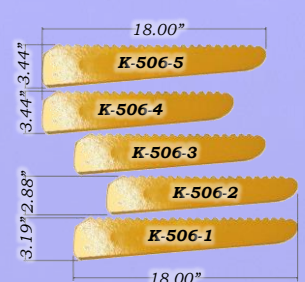

- "5 Key" = 1/4" Oversized, longer length
- "4 Key" = 1/4" Oversized standard length
- "3 Key" = Standard sized and Length
- "2 Key" = 1/4" Undersized standard length
- "1 Key" = 1/4" Undersized, longer length

®Is a registered trademark of the respectively named Company.

All manufacturer's names, numbers, symbols and descriptions are used for reference purposes only.

H&L® Wear Shrouds for P&H 4100 WH-12 Shovels

© H&L Tooth Company 2018

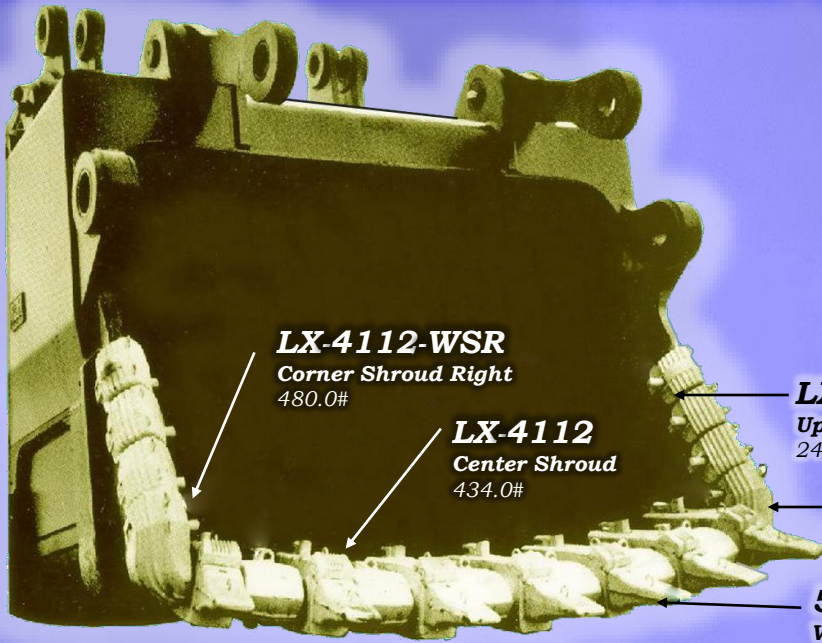

LX-4112-WSR
Corner Shroud Right
480.0#

LX-4112
Center Shroud
434.0#

LX-4112-UWS
Upper Wing Shroud
245.0#

LX-4112-WSL
Corner Shroud Left
480.0#

512-TWC-546
Whisler12 Base Assembly
1240.0#



LX-4112-UWS
Upper Wing Shroud
3 per side

K-1328 & K-1329
Wedge Key & Clamp for
Uppers and Lower



LX-4112 Dimensional Checks

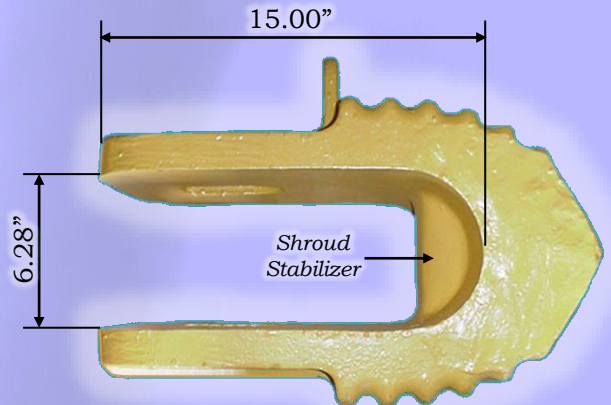

LX-4112-WSR & WSL Corner Shrouds



LX-4112 Center Shroud

K-1326 & K-1327
Wedge Key & Clamp for
Centers



1-800-HL TOOTH

® is a registered trademark of the respectively named Company.

All manufacturer's names, numbers, symbols and descriptions are used for reference purposes only.

H&L® Wear Shrouds for Bucyrus WH-12 Shovels

© H&L Tooth Company 2018



LX-4950-UCR
Upper Corner Right Shroud
348.0#

LX-4950-UCL
Upper Corner Left Shroud
348.0#

LX-4950-LCR
Lower Corner Right Shroud
366.0#

LX-4950-LCL
Lower Corner Left Shroud
366.0#

LX-4950-12
Center Shroud
518.0#

512-TWC-546
Whisler12 Base Assembly
1240.0#

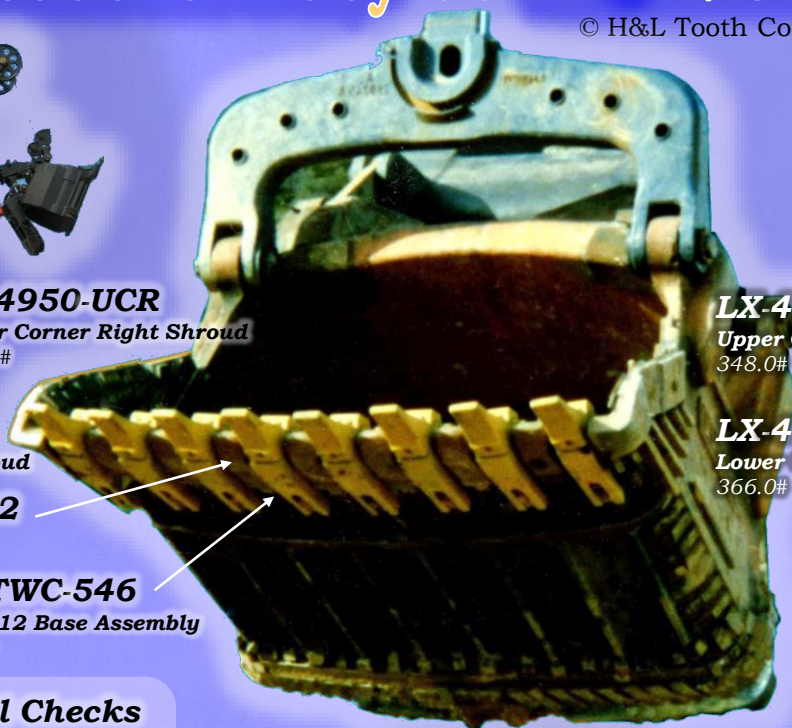

LX-4950-12 Dimensional Checks

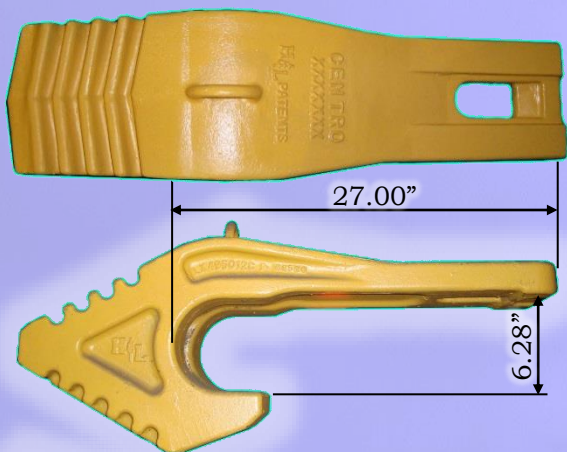

LX-4950-LCL
LX-4950-LCR
Lower Corner Left & Right

LX-4950-UCL
LX-4950-UCR
Upper Corner Left & Right



K-1348 & K-1349
Wedge Key & Clamp
for Centers



K-1358 & K-1359
Hammerless Connection
for Centers



K-1354-A & B
Dovetail Key & Clamp
for Upper & Lower Corners



K-1360 & K-1361
Hammerless Connection for
Upper & Lower Corners

® is a registered trademark of the respectively named Company.
All manufacturer's names, numbers, symbols and descriptions are used for reference purposes only.

H&L® Caterpillar Style Ripper Teeth and Shanks

© H&L Tooth Company 2018

“Always use the longest tip that will rip without excessive breakage.”

quote Caterpillar's Handbook of Ripping 2/2000

R-450 SERIES

HL-9W-2451

33.0#
Short
Centerline

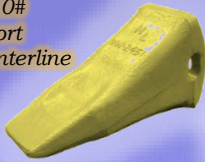

HL-9W-2452ST

40.0#
Star Rib
Design

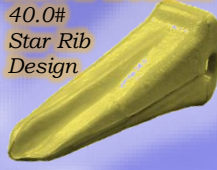

HL-9W-4453

43.0#
Long
Centerline



R-500 SERIES

HL-4T-4502ST

65.0#
Star Rib
Design

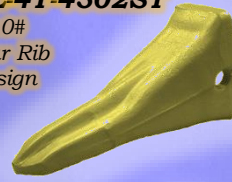

HL-4T-4503

66.0#
Long
Centerline



R-550 SERIES

CX-6Y-3552

95.5#
Intermediate
Penetrator



D11 and D10 Ripper Shanks

Model	Part Number	Weight	Width	Depth	Length	Holes	Series
D11	HL-104-9275	2630.0#	4.33"	17.75"	129.62"	3	R-550
D11	HL-104-9277	2180.0#	4.33"	17.75"	107.50"	4	R-550
D11, D10	HL-3G-6507	1330.0#	3.94"	15.75"	81.31"	2	R-500
D11, D10	HL-6Y-5616	1380.0#	3.94"	15.75"	77.85"	2	R-500
D11	HL-8E-0467	2180.0#	4.33"	17.75"	107.50"	4	R-550
D11, D10	HL-8E-8413	1380.0#	3.94"	15.75"	77.85"	2	R-500
D10	HL-118-2140	1570.0#	3.94"	15.75"	98.80"	3	R-500
D10	HL-1U-4592	1860.0#	3.94"	15.75"	110.62"	4	R-500
D10, D9	HL-3G-2088	1220.0#	3.50"	14.00"	91.65"	3	R-500
D10, D11	HL-3G-6507	1330.0#	3.94"	15.75"	81.31"	2	R-500
D10	HL-6Y-4679	1860.0#	3.94"	15.75"	110.62"	4	R-500
D10, D11	HL-6Y-5616	1380.0#	3.94"	15.75"	77.85"	2	R-500
D10, D9	HL-6Y-6138	1220.0#	3.50"	14.00"	91.65"	3	R-500
D10, D9	HL-6Y-6141	940.0#	3.50"	14.00"	71.75"	2	R-500
D10	HL-6Y-6144	1409.0#	3.50"	15.00"	111.20"	3	R-500
D10	HL-6Y-6147	1409.0#	3.50"	15.00"	111.20"	3	R-500
D10	HL-7T-5131	1380.0#	3.94"	15.75"	77.85"	2	R-500
D10	HL-8E-8411	1420.0#	3.50"	14.00"	98.80"	3	R-500
D10	HL-8E-8413	1380.0#	3.94"	15.75"	77.85"	2	R-500
D10, D9	HL-8E-8414	1285.0#	3.50"	14.00"	91.50"	3	R-500
D10, D9	HL-8E-8415	940.0#	3.50"	14.00"	71.75"	2	R-500
D10	HL-8E-8417	1680.0#	3.50"	15.00"	118.00"	3	R-500
D10	HL-9J-5954	998.0#	3.50"	14.00"	71.00"	2	R-500
D10	HL-9W-4426	1220.0#	3.50"	14.00"	91.65"	3	R-500

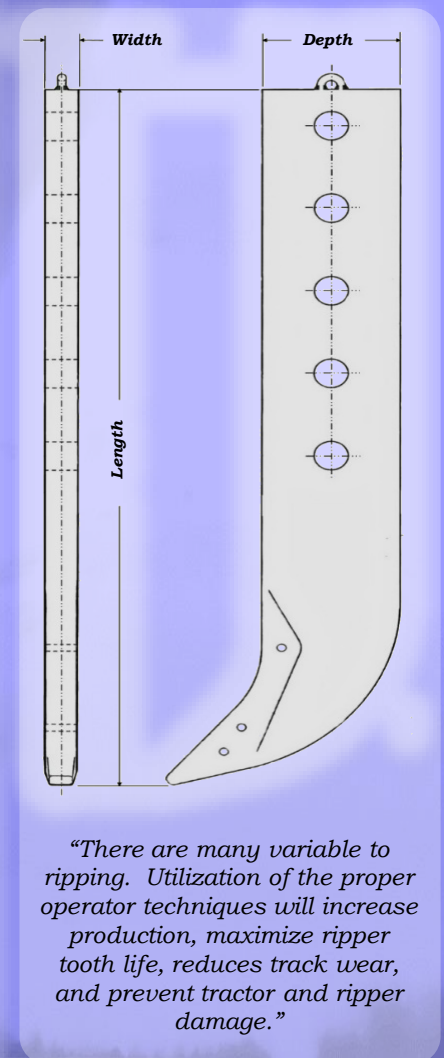

1-800-HL TOOTH

®Is a registered trademark of the respectively named Company.

All manufacturer's names, numbers, symbols and descriptions are used for reference purposes only.

H&L® Caterpillar Style Ripper Shanks, Pins and Retainer

© H&L Tooth Company 2018

D 9 and D 8 Ripper Shanks

Model	Part Number	Weight	Width	Depth	Length	Holes	Series
D 9	HL-114-4503	1285.0#	3.50"	14.00"	90.50"	3	R-500
D 9, D10	HL-3G-2088	1220.0#	3.50"	14.00"	91.65"	3	R-500
D 9	HL-3G-8566	1860.0#	3.94"	15.75"	110.65"	4	R-500
D 9, D 8	HL-4T-8988	1397.0#	3.00"	13.00"	108.50"	3	R-450
D 9, D 8	HL-4T-8990	700.0#	3.00"	13.00"	63.20"	2	R-450
D 9, D10	HL-6Y-6138	1220.0#	3.50"	14.00"	91.65"	3	5-500
D 9, D10	HL-6Y-6141	940.0#	3.50"	14.00"	71.75"	2	R-500
D 9	HL-7J-1793	1475.0#	3.50"	14.00"	106.30"	6	R-450
D 9	HL-7J-1794	765.0#	3.00"	13.00"	69.20"	2	R-450
D 9	HL-7J-1795	765.0#	3.00"	13.00"	62.20"	2	R-450
D 9	HL-8E-5339	940.0#	3.00"	13.00"	91.80"	3	R-450
D 9, D 8	HL-8E-5346	650.0#	3.00"	13.00"	63.40"	2	R-450
D 9, D10	HL-8E-8414	1285.0#	3.50"	14.00"	91.50"	3	R-500
D 9, D10	HL-8E-8415	940.0#	3.50"	14.00"	71.75"	2	R-500
D 9	HL-9W-6167	1120.0#	3.00"	13.00"	91.65"	3	R-450
D 8	HL-4T-0134	1120.0#	3.00"	13.00"	96.60"	3	R-450
D 8	HL-4T-0135	830.0#	3.00"	13.00"	75.00"	3	R-450
D 8	HL-4T-0136	600.0#	3.00"	13.00"	59.50"	2	R-450
D 8	HL-4T-5340	1112.0#	3.00"	13.00"	96.60"	3	R-450
D 8, D 9	HL-4T-8988	1397.0#	3.00"	13.00"	108.50"	3	R-450
D 8	HL-4T-8989	850.0#	3.00"	13.00"	79.35"	3	R-450
D 8, D 9	HL-4T-8990	700.0#	3.00"	13.00"	63.20"	2	R-450
D 8, D 9	HL-8E-5346	650.0#	3.00"	13.00"	63.40"	2	R-450
D 8	HL-8E-5347	830.0#	3.00"	13.00"	79.35"	3	R-450

Full FACTORY WARRANTY

ON ALL H&L PRODUCTS.

Meets or exceeds OEM requirements All dimensions are for reference only.

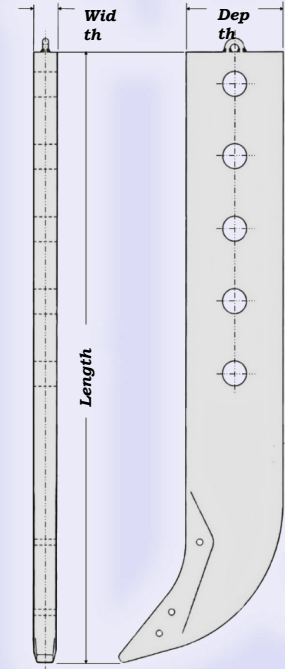

"There are many variable to ripping. Utilization of the proper operator techniques will increase production, maximize ripper tooth life, reduces track wear, and prevent tractor and ripper damage."

Cat Ripper Style Pins and Retainers

Series	Part Number	OD	Length	Other Part Numbers
R-200	HL-9W-7112	0.433"	2.36"	8E-6208, 1U-4208
R-250	HL-9J-2258P	0.551"	3.01"	132-4763
R-300	HL-9W-2668	0.750"	3.38"	136-8308, 9J-2358, 2W-2668
R-350	HL-8E-6358	0.748"	4.13"	9W-2678, 114-0358
R-450	HL-6Y-3394	0.995"	5.00"	6Y-3394 (Bucket Type) 138-6450 (HD)
R-500	HL-6Y-1204	1.260"	5.60"	6Y-3907 (Bucket Type) 6Y-1204 (Impact) 138-6508 (HD)
R-550				8E-2229 (Bucket Type) 9N-4245 (Impact) 159-0558 (HD)

Series	Part Number	ID	OD	Other Part Numbers
R-200	HL-4T-0001	0.417"	0.91"	8E-6209
R-250	HL-3G-9609	0.535"	1.18"	133-0609
R-300	HL-1U-2405	0.720"	1.50"	114-0359, 7J-6845
R-350	HL-1U-2405	0.720"	1.50"	114-0359, 7J-6845
R-450	HL-8E-4743	0.970"	1.88"	8E-4743 (Bucket Type) 107-8559 (HD)
R-500	HL-6Y-1202	1.240"	2.50"	4T-4707 (Bucket Type) 6Y-1202 (Impact) 113-4709 (HD)
R-550				8E-2230 (Bucket Type) 6Y-1205 (Impact) 134-1809 (HD)

Compression Ring Hardware for R-Series Caterpillar Ripper Shanks

Series	Part Number	OD	Length	Other Part Numbers
R-450	HL-4T-2479	1.000"	4.69"	7J-9600
R-500	HL-3G-0500	1.250"	6.00"	102-9062
R-550				6Y-2443

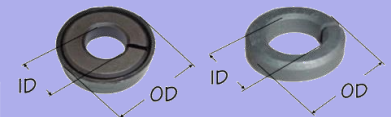
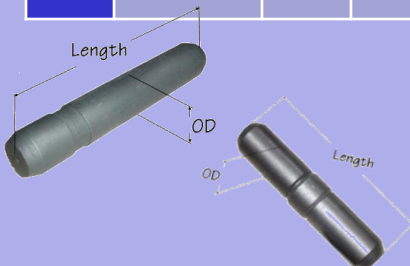

Retainers may or may not have plastic shells.

® is a registered trademark of the respectively named Company.

All manufacturer's names, numbers, symbols and descriptions are used for reference purposes only.

H&L® Komatsu® Style Ripper Teeth, Shanks and Pin Hardware

© H&L Tooth Company 2018

KR1 SERIES

175-78-31230

33.0#
Models D80, D85E
and D90S



H&L No.
HL-175-78-31230
Long Tooth

KR2 SERIES

195-78-21331

44.8#
Model D355



H&L No.
HL-195-78-21331
Short Tooth

KR2A SERIES

195-78-71320

53.8#
Model D455



H&L No.
HL-198-78-71320ST
Star Tooth

KR3 SERIES

198-79-11230

50.0#
Model D455



H&L No.
HL-198-79-11230
Short Tooth

198-79-11551

56.0#
Model D455



H&L No.
HL-198-79-11550
Short Tooth

H&L® Komatsu® Style Ripper Shanks

Ripper Shanks by length of Shank

Model	Part Number	Weight	Width	Depth	Length	Holes	Series
DRT031	HL-113-78-21130	35.0#	1.56"	4.50"	20.19"	1	
D85-1B, D85-21, D90S	HL-154-78-14344	384.0#	3.00"	9.00"	50.88"	2	KR1
D135, D150, D155	HL-175-78-21613	605.0#	3.00"	12.00"	63.88"	2	KR1
D155	HL-175-78-21614	598.0#	3.00"	12.88"	64.88"	2	KR1
D275, D355	HL-195-78-41191	700.0#	3.50"	14.25"	72.00"	2	KR2
D355A-2, D455A-1	HL-195-78-41190	700.0#	3.50"	14.00"	72.69"	2	KR2
D-375-2, D375A-5	HL-195-78-71310	930.0#	3.50"	14.18"	74.25"	2	KR2A
D375-1, D375A-5	HL-195-78-71120	930.0#	3.50"	14.18"	74.25"	2	KR2
D355A-2	HL-175-79-32130	962.0#	3.50"	14.00"	79.00"	4	KR2
D455A-1	HL-198-78-11240	1340.0#	3.75"	15.75"	84.50"	2	KR3
D275A-2, 355A-3, D455	HL-195-79-31140	1350.0#	3.75"	15.75"	86.38"	4	KR2
D375A-3A	HL-195-79-51151	1400.0#	3.75"	15.75"	87.50"	3	KR2A
D455A-1, D475	HL-198-79-11630	1950.0#	4.38"	18.25"	111.25"	5	KR3

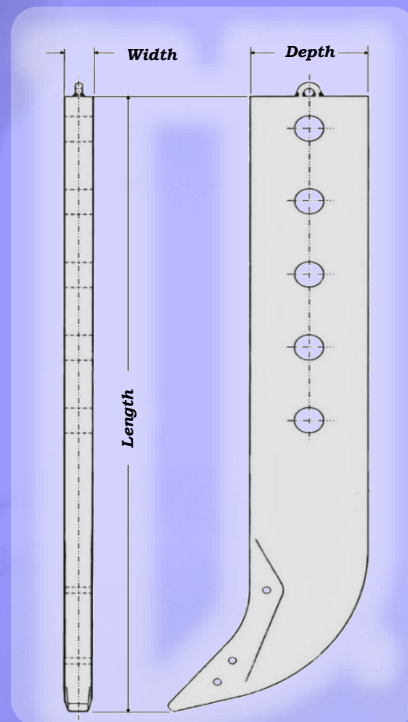

Ripper Pin Attachment Hardware

**Compression
Ring Hardware
for Komatsu
KR-Series
Ripper Teeth**

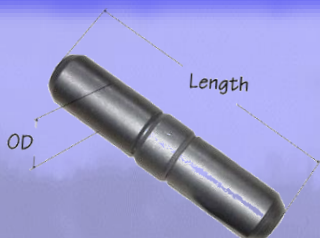

Series	Part Number	OD	Length	Other #
KR1 & KR2	HL-175-78-21740	0.970"	4.25"	175-78-21810
KR2	HL-195-78-71360	1.175"	4.38"	
KR2A	HL-198-79-11320	1.175"	5.38"	
KR3	HL-092-44-03036	1.175"	5.88"	

®Is a registered trademark of the respectively named Company.

All manufacturer's names, numbers, symbols and descriptions are used for reference purposes only.

H&L® MINING GAUGE INSPECTION

© H&L Tooth Company 2018

UNIVERSAL Whisler Key/Clamp Hole Gauge

H&L® X-2562-N Hole Gauge

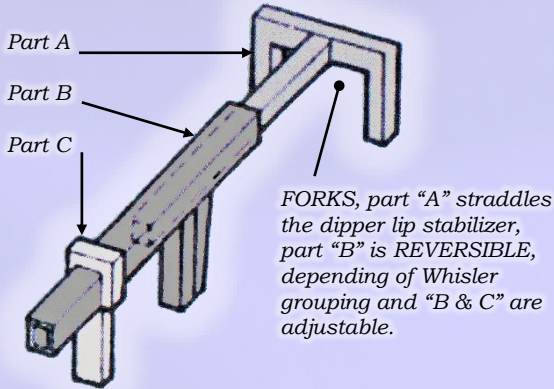

This gauge will check the slot hole location of WH 4, WH 6, WH 8, WH10 and WH12 Lip fits.

It is for approximate dimension checks only.

Example of WH-10 Dipper Lip

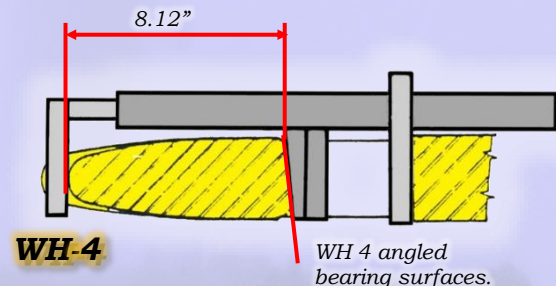
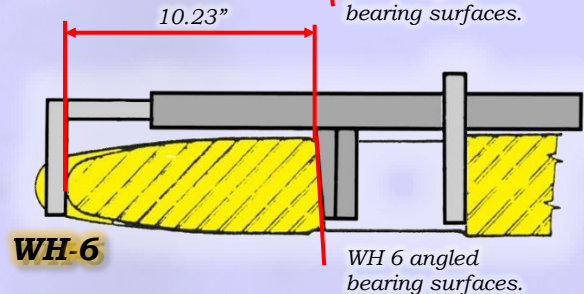
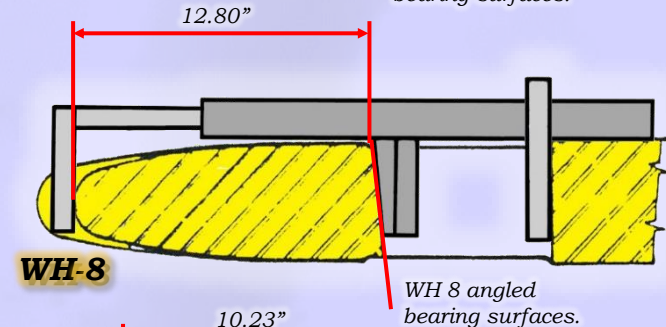
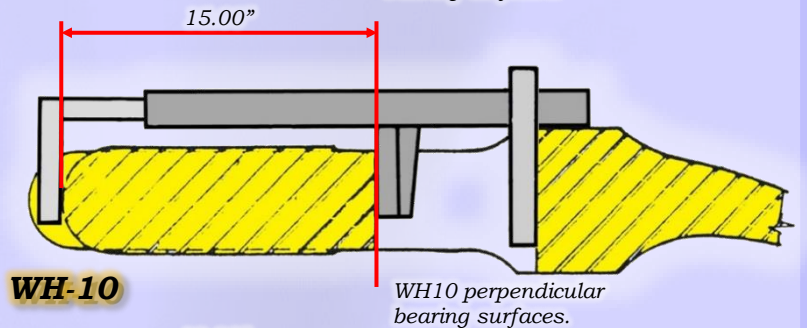
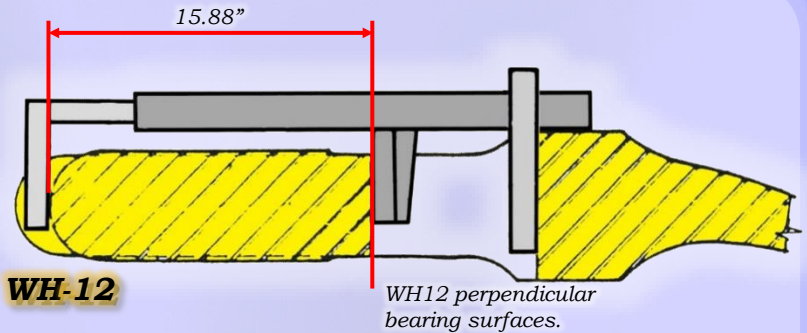
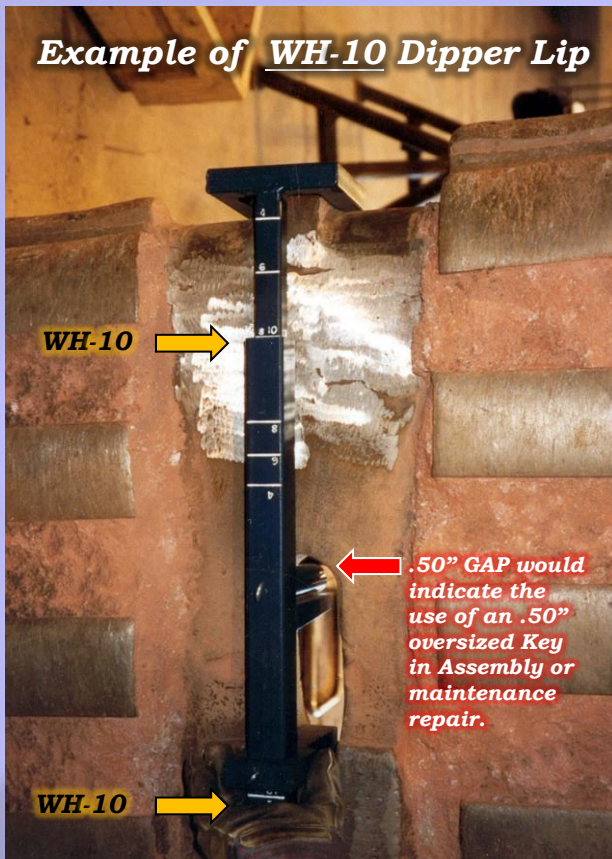

® is a registered trademark of the respectively named Company.

All manufacturer's names, numbers, symbols and descriptions are used for reference purposes only.

H&L® MINING GAUGE INSPECTION

© H&L Tooth Company 2018

Lip Maintenance Repair and Grinding Gauges



When there are no **OEM** specifications or guidelines by the machine manufacture for Whisler connection lip repair H&L® offers a complete line of lip gauges.

It is H&L's recommendation to the mine maintenance personnel reworking Whisler lips to take nothing for granted.

X-2562-AD WH 12 Lip Check

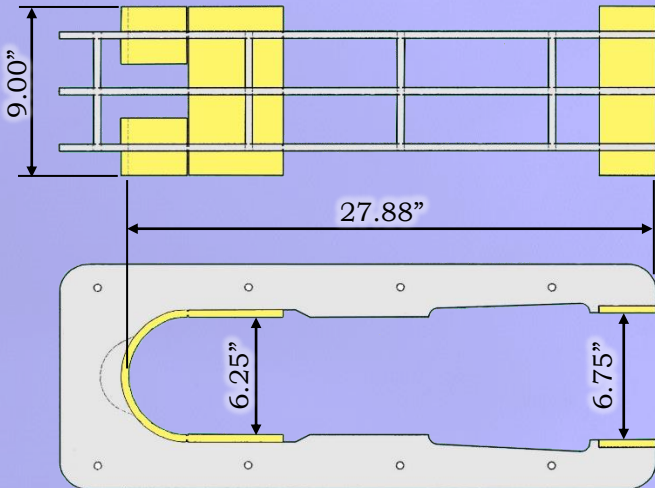

X-2562-V WH 10 Lip Check

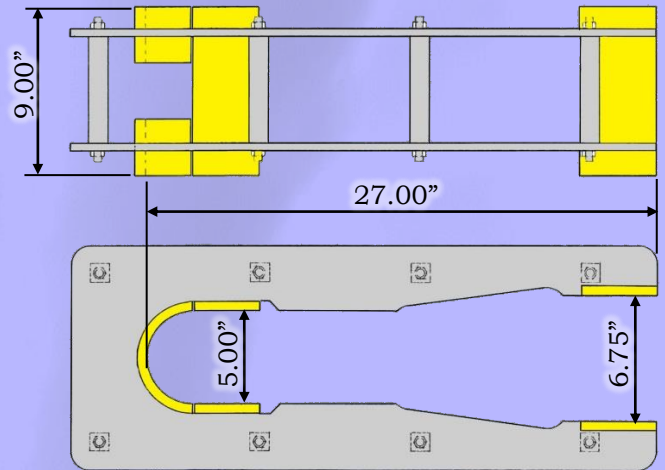

X-2562-R WH 8 Lip Check

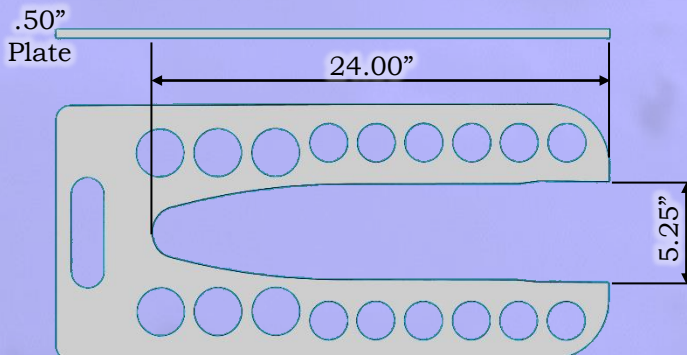

Whisler 8 lip gauge is constructed as a single plate it is not a box type gauge like the WH10 and WH 12.

X-2562-T WH 6 Lip Check

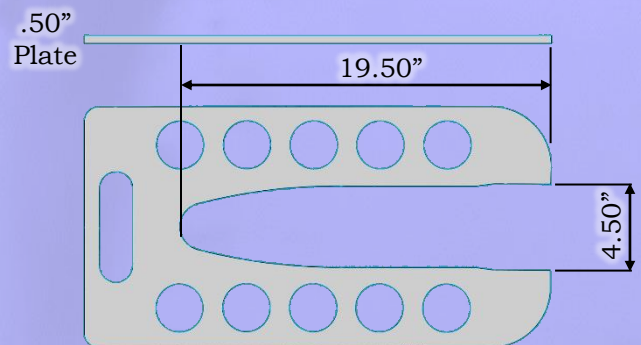

Whisler 6 lip gauge is constructed as a single plate it is not a box type gauge like the WH10 and WH 12.

®Is a registered trademark of the respectively named Company.

All manufacturer's names, numbers, symbols and descriptions are used for reference purposes only.

H&L® MINING Products... Weld-On Excavator Style Adapters

© H&L Tooth Company 2018

Custom Adapters for any bucket!

H&L style Mining Style Adapters may not be a stocking item, call Customer Service to check availability.

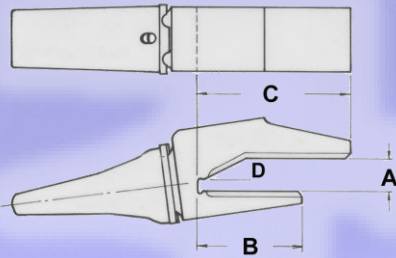

“VP” Vertical-Pin Adapter System Adapter

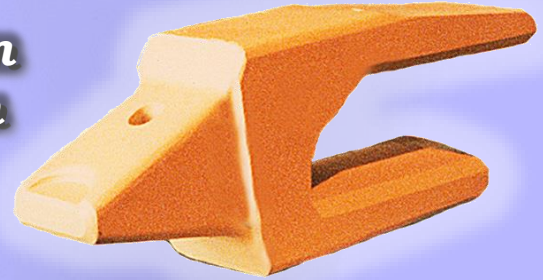

“1W” Excavator Adapter

Application Model	Part Number	Style	A	B	C	D	Weight
Replaces Esco 3811-V61	3764-W-541	1W	2.36"	6.75"	13.50"	30°	115.0#
Replaces Esco 3858-V61	3765-W-541	1W	2.75"	6.75"	13.50"	30°	115.0#
Replaces Esco 5898-V61	3766-W-541	1W	3.15"	8.00"	15.50"	30°	130.0#
Replaces Esco 5898-V69	3766-W-543	1W	3.15"	8.00"	15.50"	30°	140.0#
P&H 1200	3704-AW-541	1W	5.50"	12.00"	17.25"	25°	240.0#
Replaces Esco 2878-V61	3767-W-541	1W	3.50"	8.94"	16.00"	30°	130.0#
Replaces Esco 2878-V69	3767-W-543	1W	3.50"	8.94"	16.00"	30°	140.0#
Replaces Esco 6803-V69	3773-W-543	1W	3.50"	8.00"	16.00"	30°	175.0#
Replaces Esco 2837-V69	3775-W-543	1W	3.50"	9.70"	20.50"	30°	255.0#
Replaces Esco 2837-V71	3775-W-546	1W	3.50"	9.70"	20.50"	30°	265.0#
Replaces Esco 6805-V61	3768-W-541	1W	3.54"	7.75"	15.50"	30°	120.0#
Replaces Esco 6805-V69	3768-W-543	1W	3.54"	7.75"	15.50"	30°	130.0#
Replaces Esco 6804-V69	3774-W-543	1W	3.94"	8.00"	16.00"	30°	170.0#
Replaces Esco 6804-V71	3774-W-546	1W	3.94"	8.00"	16.00"	30°	180.0#
P&H 1550	3708-AW-541	1AW	4.00"	20.00"	20.00"	45°	245.0#
Replaces Esco 5897-V71	3776-W-543	1W	4.00"	9.70"	20.50"	30°	255.0#
Replaces Esco 5897-V81	3776-W-546	1W	4.00"	9.70"	20.50"	30°	265.0#
Replaces Esco 3869-V81	3779-W-546	1W	4.75"	13.00"	22.00"	30°	350.0#
Replaces Esco 6801-V81	3780-W-546	1W	5.00"	13.00"	22.00"	30°	350.0#
P&H 2550	3709-W-546	1W	5.50"	10.00"	20.00"	45°	370.0#
Hitachi 3500	3720-W-546	1W	5.50"	13.00"	19.00"	30°	425.0#
Replaces Esco 6806-V81	3781-W-546	1W	5.50"	13.00"	22.00"	30°	420.0#



Excavator Bucket Adapter



Excavator Bucket with Lip Protectors

Quality Control Personnel gauge inspects every 500-Series tooth produced, to ensure optimum for between adapter-nose and tooth pocket bearing surfaces. H&L® Flexho!® attachments keep teeth tight to the mating adapter nose, lowering maintenance costs by minimizing equipment downtime!

Flexho!® Installation and Removal



Push the elastomer Insert into the adapter nose until flange is flush with the nose top surface.

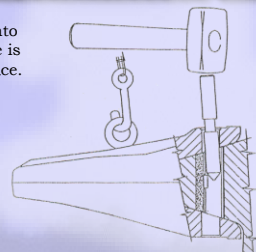
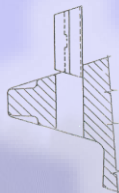

Position one of the “VP” style Series Mining tooth on the adapter nose.

Insert SOLID STEEL pin as shown and drive until locked into the elastomer Insert. Pin will be flush with the top of the tooth.

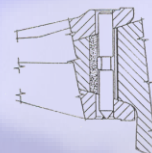

®Is a registered trademark of the respectively named Company.

All manufacturer’s names, numbers, symbols and descriptions are used for reference purposes only.

H&L® MINING Products... Weld-On Loader Style Adapters

© H&L Tooth Company 2018

“VP” Vertical-Pin Adapter System Adapter



“1W” Loader Adapter

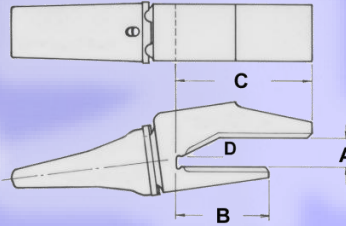

Quality Control Personnel gauge inspects every 500-Series tooth produced, to ensure optimum fit between adapter-nose and tooth pocket bearing surfaces. H&L® Flexho!® attachments keep teeth tight to the mating adapter nose, lowering maintenance costs by minimizing equipment downtime!

Application Model	Part Number	Style	A	B	C	D	Weight
Replaces Esco 5869-V61	L-3769-W-541	1W	2.50"	8.50"	14.38"	25°	120.0#
Caterpillar 992 - 9W-9704	L-3782-W-541	1W	2.50"	13.50"	17.50"	23°	160.0#
Caterpillar 992 - 9W-9704	L-3782-W-543	1W	2.50"	13.50"	17.50"	23°	160.0#
Komatsu WA-600 Loader	L-6016-W-541	1W	2.75"	6.75"	13.50"	25°	115.0#
Komatsu WA-600 Loader	L-6016-W-543	1W	2.75"	6.75"	13.50"	25°	115.0#
Replaces Esco 1856-V61	L-3770-W-541	1W	3.00"	8.75"	16.50"	25°	135.0#
Caterpillar 992 - 4T-4707	L-3783-W-543	1W	3.00"	13.50"	18.00"	23°	160.0#
Caterpillar 992 - 4T-4707	L-3783-W-543	1W	3.00"	13.50"	18.00"	23°	160.0#
Replaces Hensley 358-944	L-3784-W-543	1W	3.50"	10.50"	20.00"	30°	220.0#
Replaces Hensley 358-944	L-3784-W-546	1W	3.50"	10.50"	20.00"	30°	220.0#
Replaces Esco 5838-V61	L-3771-W-543	1W	3.50"	8.75"	17.00"	30°	130.0#
Replaces Esco 5838-V69	L-3771-W-546	1W	3.50"	8.75"	17.00"	30°	140.0#
Replaces Esco 5839-V61	L-3772-W-543	1W	3.50"	8.19"	16.50"	30°	145.0#
Replaces Esco 5839-V69	L-3772-W-546	1W	3.50"	8.19"	16.50"	30°	155.0#
Replaces Esco 5839-V69	L-3772-W-546	1W	3.50"	8.19"	16.50"	30°	155.0#
Replaces Esco 5894-V81	L-3777-W-546	1W	4.00"	10.50"	21.50"	30°	250.0#
Replaces Esco 5896-V81	L-3778-W-546	1W	4.00"	9.70"	21.00"	30°	260.0#
Caterpillar 994 - 6I-8804	L-3785-W-546	1W	4.00"	13.50"	17.50"	23°	225.0#

RIGHT HAND AND LEFT HAND also available on request.

Adapter is cut for a degree right and left hand spade lip edge.



RIGHT & LEFT HAND CORNERS also available on request.

Adapter is cut to match bucket side plates.



EXTRA WEAR PROTECTION also available on request.

Adapter uses a CX-2772-HD Weap Cap Protector.



H&L® Weld-On Mining repair Nosepieces for Loaders, Face Shovels and Excavator adapters!

Applications	Part Number	Angle	A	B	Tooth	Weight
541 Repair or conversion	NP-541-B	Fixed	2.50"	8.50"	541	85.0#
541 Repair or conversion	NP-541-C	Adjustable	2.50"	13.50"	541	85.0#
543 Repair or conversion	NP-543-B	Fixed	2.50"	13.50"	543	95.0#
543 Repair or conversion	NP-543-C	Adjustable	2.75"	6.75"	543	95.0#
546 Repair or conversion	NP-546-B	Fixed	2.75"	6.75"	546/646	170.0#
546 Repair or conversion	NP-546-C	Adjustable	3.00"	8.75"	546/646	172.0#

Dimensional Check

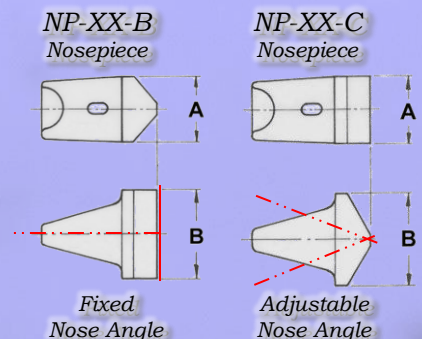

1-800-HL TOOTH

®Is a registered trademark of the respectively named Company.

All manufacturer's names, numbers, symbols and descriptions are used for reference purposes only.

Comments

Other Product Catalogs

H&L® ORIGINAL Products: Catalog #210.2018

H&L® Caterpillar® Style Products: Catalog #210.2018

H&L® Esco® Style Products: Catalog #211.2018

H&L® Hensley®, Style Products: Catalog #212.2018

H&L FACTORY WARRANTY!

The H&L Tooth Company warrants all H&L Products against defects in material and workmanship.

Tulsa Oklahoma's 200,000 square foot manufacturing home includes forging, fabrication, and heat treating facilities, and serves as our central distribution complex.



Tulsa FORGE LINE consists of multiple 4"- 6"- 7 ½"- 9" National Upsetters, 1000, 1300, 2000 Ton National MaxiPres that will produce GET Products from 2 pounds to 2000 pounds.



**Over two million GET parts in our Shipping Department in Tulsa, Oklahoma.
H&L Tooth is an ISO 9001 CERTIFIED Company.**

**Patented
Auto-Welders**

H&L Tooth Company Quality Policy

H&L Tooth commits to meeting or exceeding internal and external customer requirements in its manufacturing and processing of ground engaging tools. This will be achieved by continually improving the effectiveness of our quality system through the establishment and tracking of quality objectives, identifying opportunities for improvements, and teamwork among our employees, customers and vendors.

1-800-HL TOOTH