



H&L's 2AH Teeth are produced from aircraft quality Chrom-Moly grade alloy steels to enhance tooth **DURABILITY** and long **LASTING SHARPNESS!**



Malleable tooth pocket clip provides ease of crimping installation!

Submerged-arc welding clip-to-blade process creates maximum weld penetration!

444-514BHN  
HARDNESS!

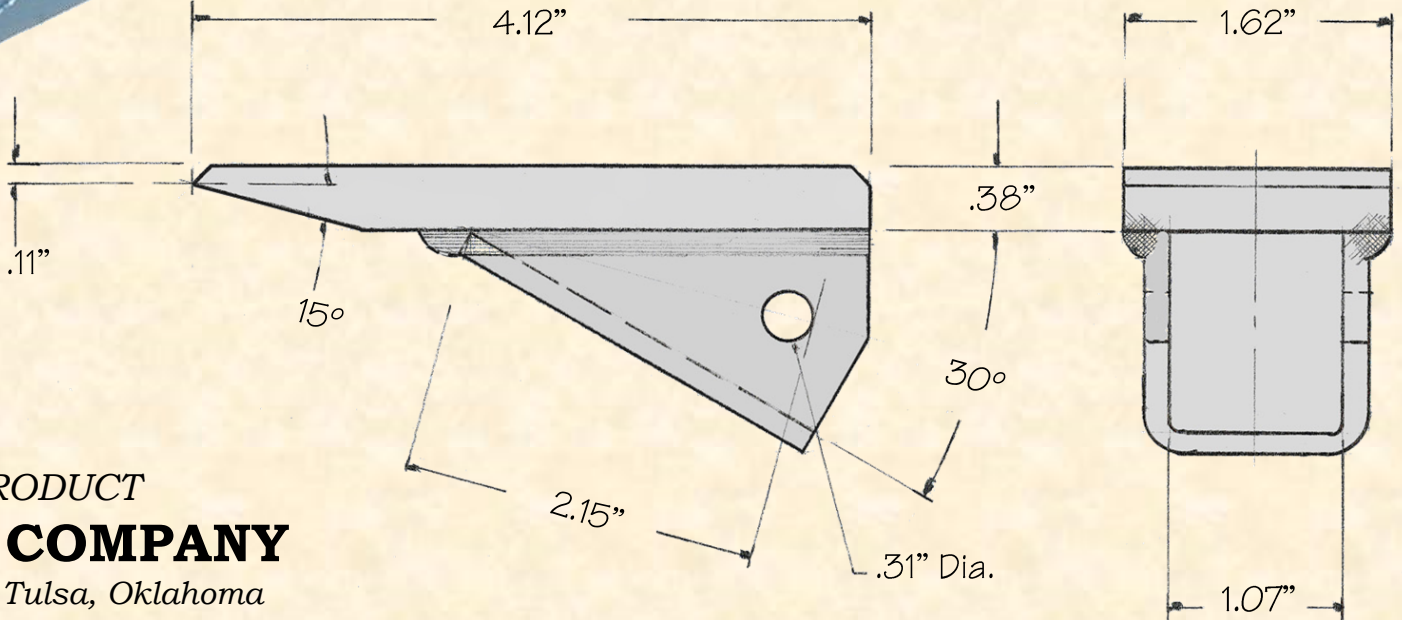

**H&L® TOOTH COMPANY**

Factory Direct Made in Tulsa, Oklahoma

The "OEM" fabrication Crimp-on tooth design

**2AH**

Heavy Penetration  
0.9#/0.41kgs.

*H&L Tooth Company History since 1931:  
This small fabricated trenching tooth was first designed and introduced in 1946. H&L's Crimp-on Tooth system was first developed to fit small Buckeye and Cleveland Wheel Trenching Machines. Today, copies of the 2AH tooth are being produced by many companies worldwide, if it doesn't say H&L its not the ORIGINAL!*