

T160.2016

QUALITY
since 1931

H&L's Snaploc Remover Tools are produced from aircraft quality Chrom-Moly-Nickel grade alloy steels to enhance adapter **DURABILITY** and **TOUGHNESS!**

© H&L Tooth Company 2016



H&L Part #3-SLP Snaploc

ORIGINAL PRODUCT

H&L® TOOTH COMPANY

Factory Direct Made in Tulsa, Oklahoma

The "OEM" Snaploc Remover Tool

X-2703 Remover Tool

Adapter-Tooth-Snaploc Pin Remover

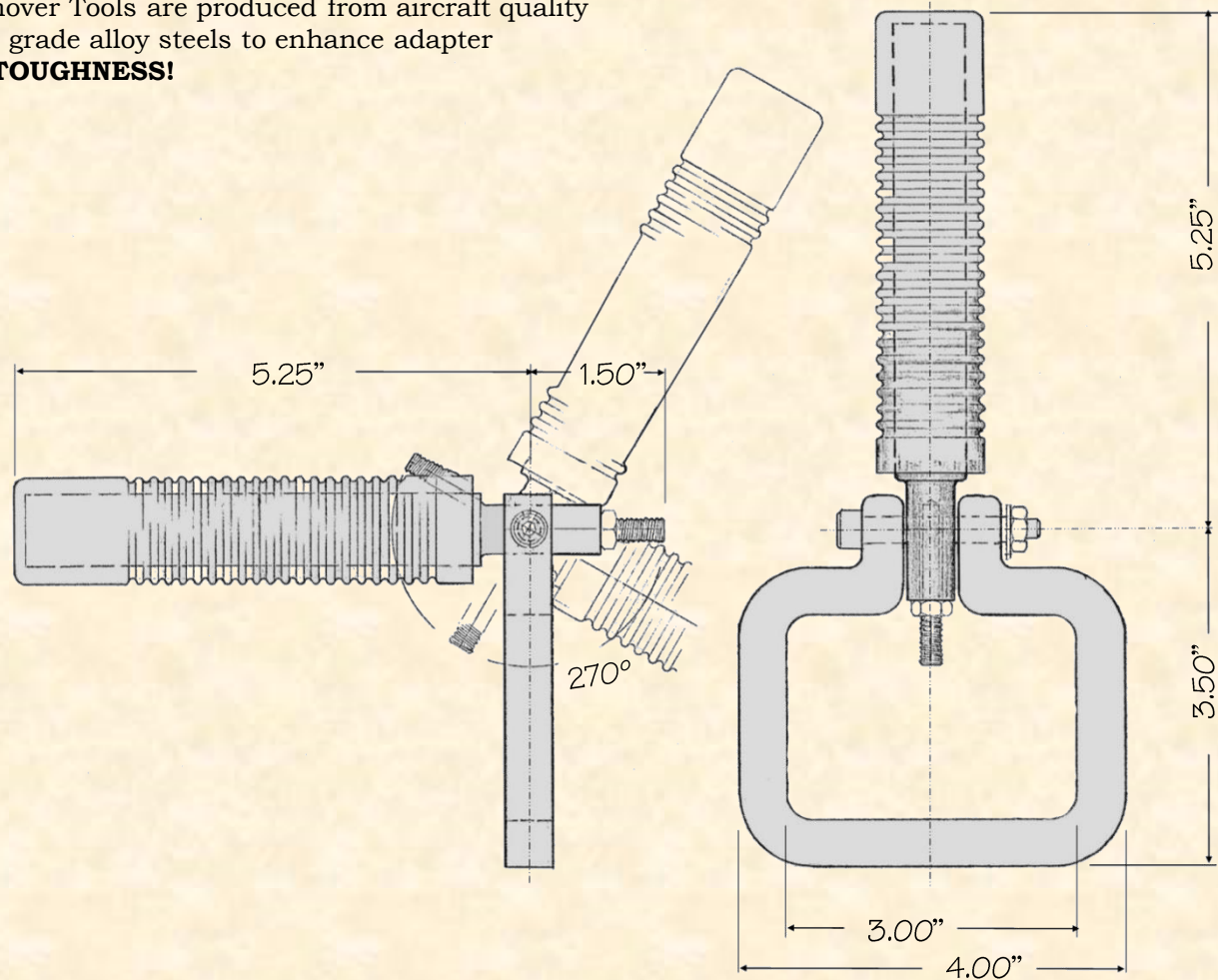

H&L Tooth Company History since 1931:

The Snaploc's original concept was developed in early 1985, H&L received a United States patent in September 1986. This Tool was designed to remove a digging tooth from the adapter. One of it's first application was for Capital Trencher in the form of a 2A and 3C trencher bucket wheel version. H&L 2X and 3X number "3-SLP" Snaploc connection became the OEM offering for Capital trenching machines during the 1980s. The locking insert went out of production as a tooth-to-nose connection by 1990 and was obsolete, the same can be said about the remover tool.