

T173.2016

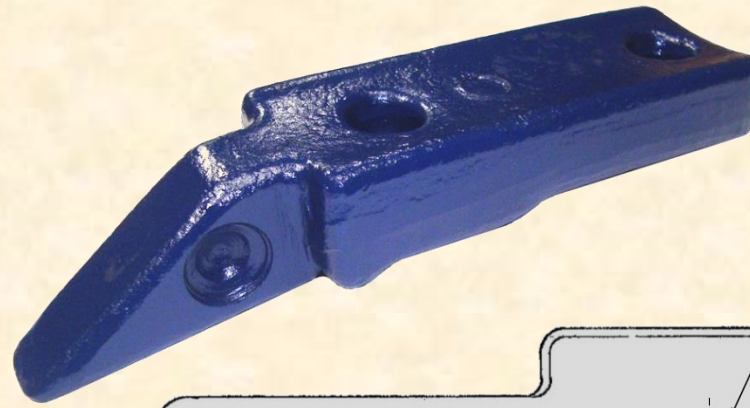

© H&L Tooth Company 2016

H&L's D-325-2A Trenching Adapters are produced from aircraft quality Chrom-Moly grade alloy steels to enhance tooth **DURABILITY** and long **LASTING SHARPNESS!**



Uses fabricated 2AH Series tooth system.

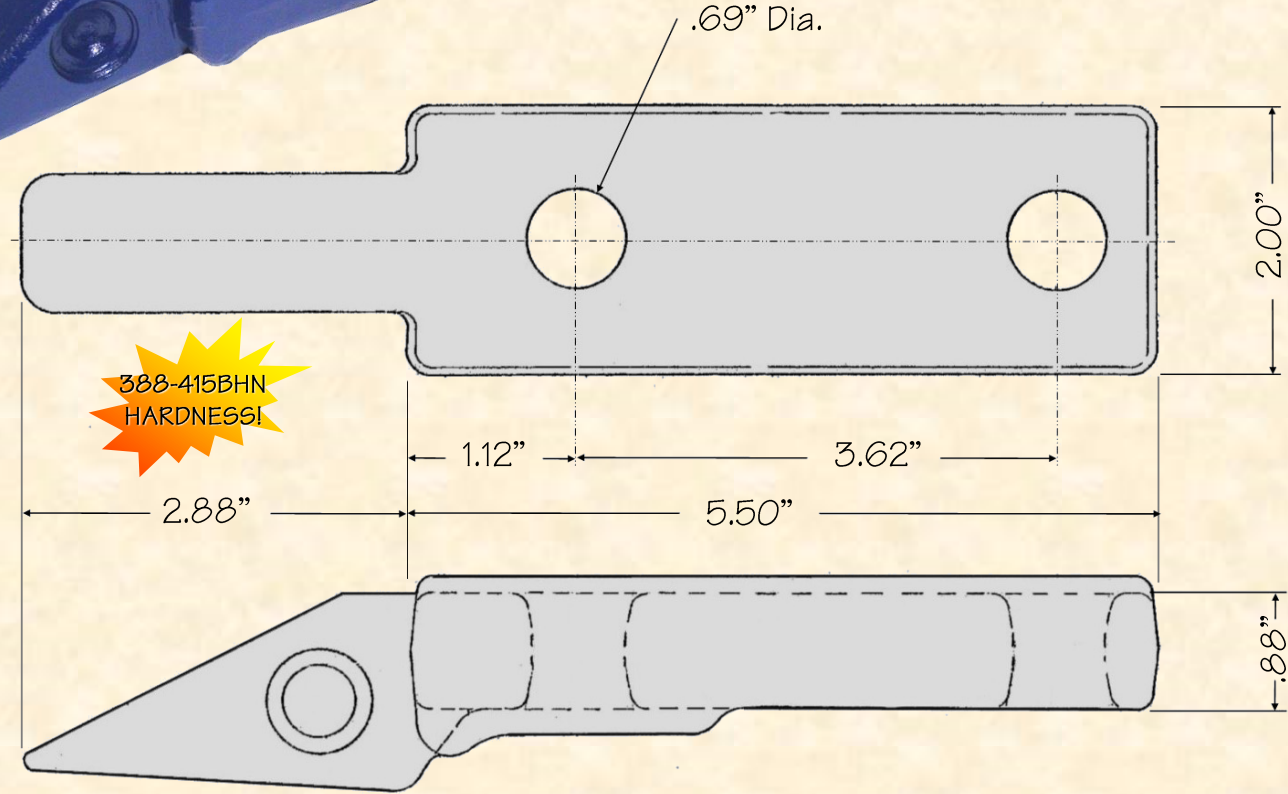

ORIGINAL PRODUCT

H&L® TOOTH COMPANY

Factory Direct Made in Tulsa, Oklahoma

The "OEM" Bolt-on adapter design

D-325-2A

Trenching Wheel Bucket Adapter
3.5#/1.58kgs.

H&L Tooth Company History since 1931:

This small bolt-on trenching adapter was first designed and introduced in 1947. H&L's adapter was developed to fit the Buckeye and Cleveland Wheel Trenching Machines.

This adapter uses the small fabricated trenching tooth that was first designed and introduced in 1946.

Today, copies of the 2AH tooth are being produced by many companies worldwide, if it doesn't say H&L its not the ORIGINAL!