

T265.2017

QUALITY
since 1931

© H&L Tooth Company 2017



H&L's L-4193-23 loader Adapters are produced from aircraft quality Chrom-Moly-Nickel grade alloy steels to enhance adapter **DURABILITY** and **TOUGHNESS!**

**388-415BHN
HARDNESS!**

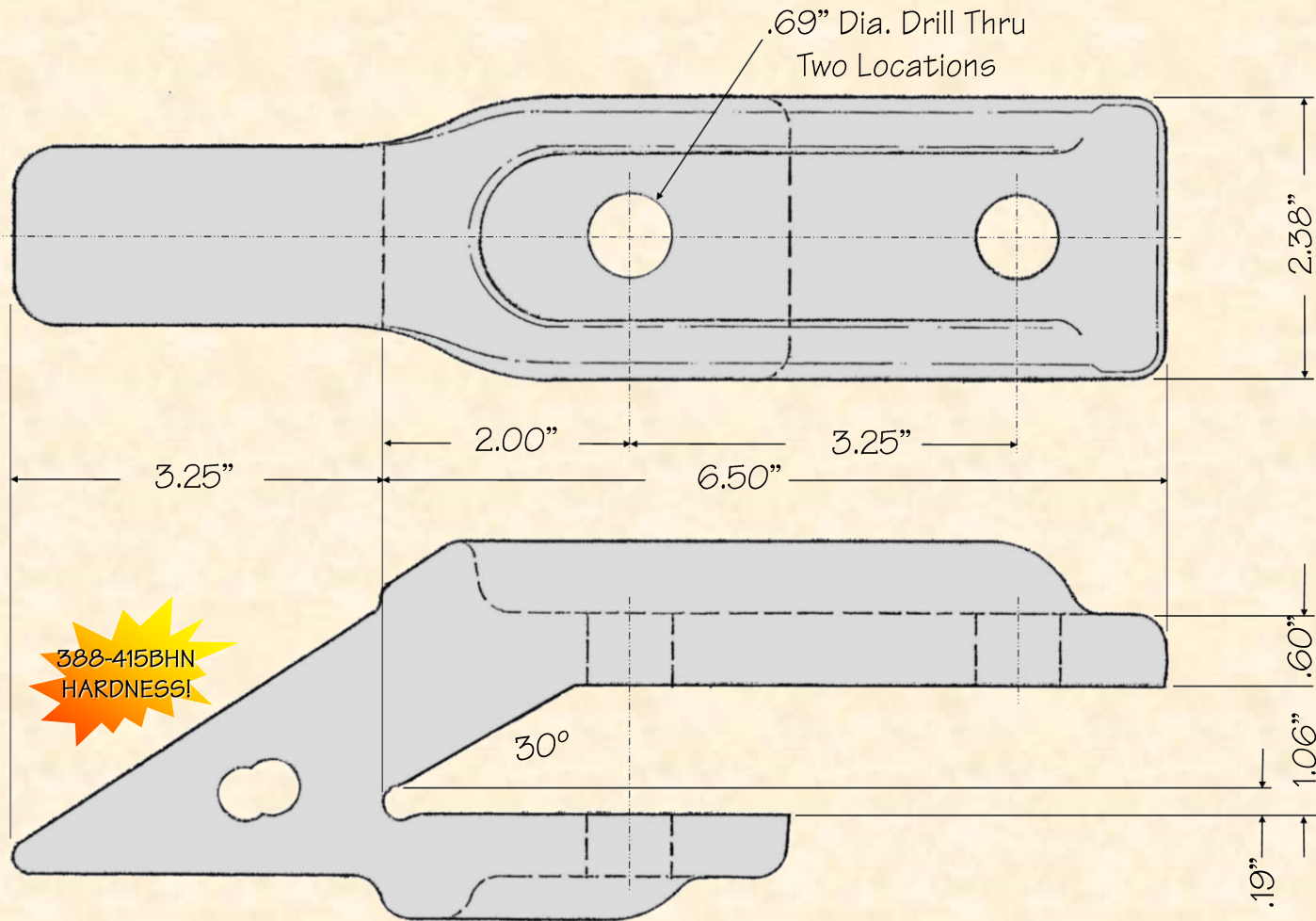

ORIGINAL PRODUCT

H&L® TOOTH COMPANY

Factory Direct Made in Tulsa, Oklahoma

The "OEM" Flexpin Style **LOADER ADAPTER** design

L-4193-23

Loader Adapter

5.0#/2.27kgs.

H&L Tooth Company History since 1931:

This Leg and a half bolt-on loader adapter was first designed and introduced by H&L Tooth in 1972 as OEM 230-110-12. It was first produced for the Ford A-62, carries Ford numbers D3NN293-A, XN-561734, XN-561477 and XN-565070.

H&L's L-4193-23 bolt-on adapter replaced the OEM adapter in 1975 and is constructed as a forging.

Today, H&L continues to produce the "Original" L-4193-23 adapter and 230-Series tooth system.