

T271.2017

QUALITY
since 1931

© H&L Tooth Company 2017



H&L's L-4242-23 loader Adapters are produced from aircraft quality Chrom-Moly-Nickel grade alloy steels to enhance adapter **DURABILITY** and **TOUGHNESS!**

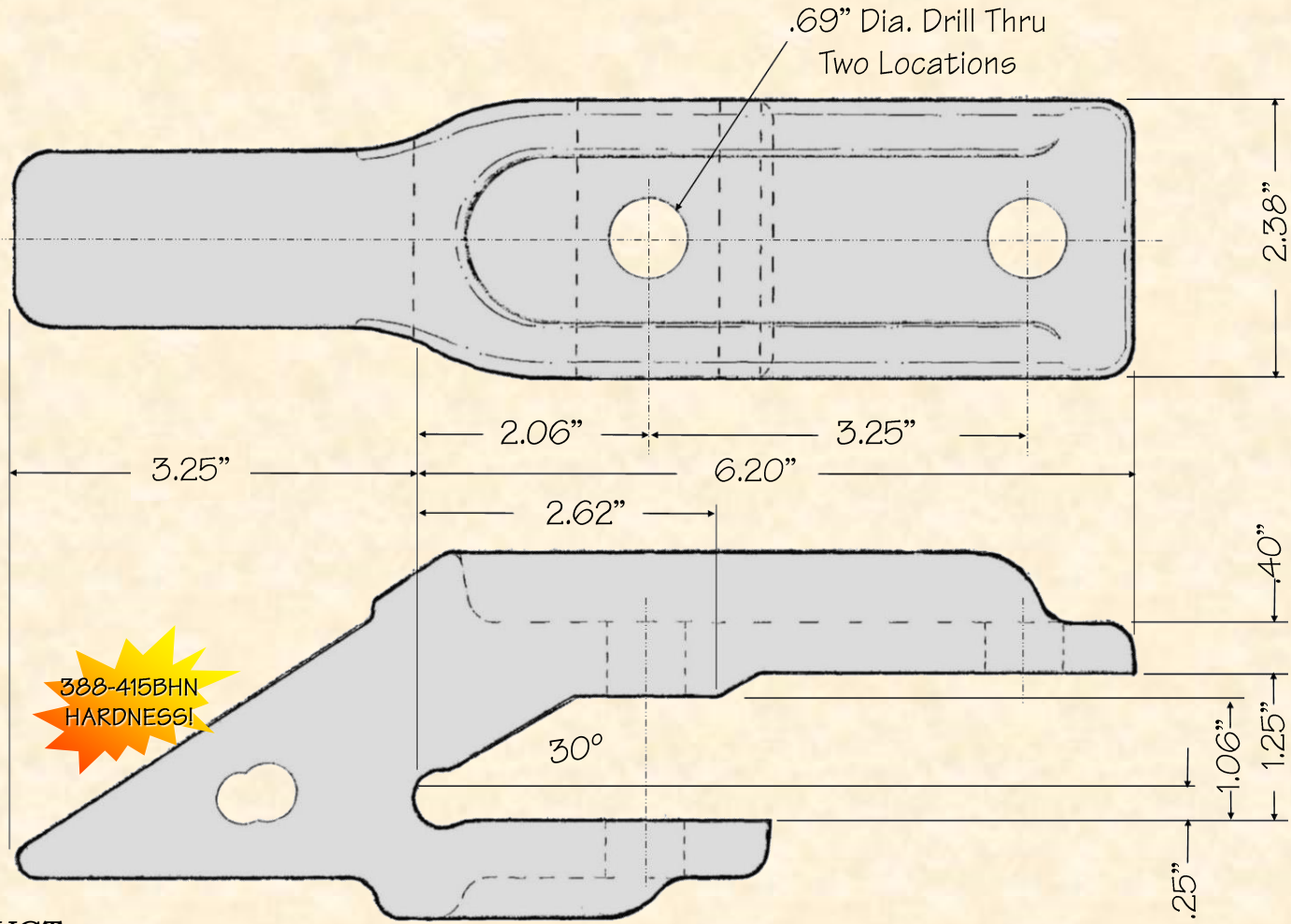

ORIGINAL PRODUCT

H&L® TOOTH COMPANY

Factory Direct Made in Tulsa, Oklahoma

The "OEM" Flexpin Style **LOADER ADAPTER** design

L-4242-23

Loader Adapter
5.0#/2.27kgs.

H&L Tooth Company History since 1931:

This Leg and a half bolt-on loader adapter was first designed and introduced by H&L Tooth in 1978 as OEM 230-112-04. It was first produced for the Gannon Manufacturing Company, part number D-10-19.

H&L's L-4242-23 bolt-on adapter replaced the OEM adapter in 1978 and is constructed as a forging.

Today, H&L continues to produce the "Original" L-4286-23 adapter and 230-Series tooth system.