

R075.2015



H&L's Cat Style HL-8E-8411 Rippers are produced from Chrom-Moly-Nickel grade alloy steels to enhance shank **DURABILITY and TOUGHNESS!**

© H&L Tooth Company 2015

Uses (R500) HL-4T-45025T-4R Tooth with HL-6Y-1204 and HL-6Y-1202 Pin and Retainer HL-9W-8365 Wear Plate with two HL-6Y-1204 with HL-6Y-1202 Pins and Retainers

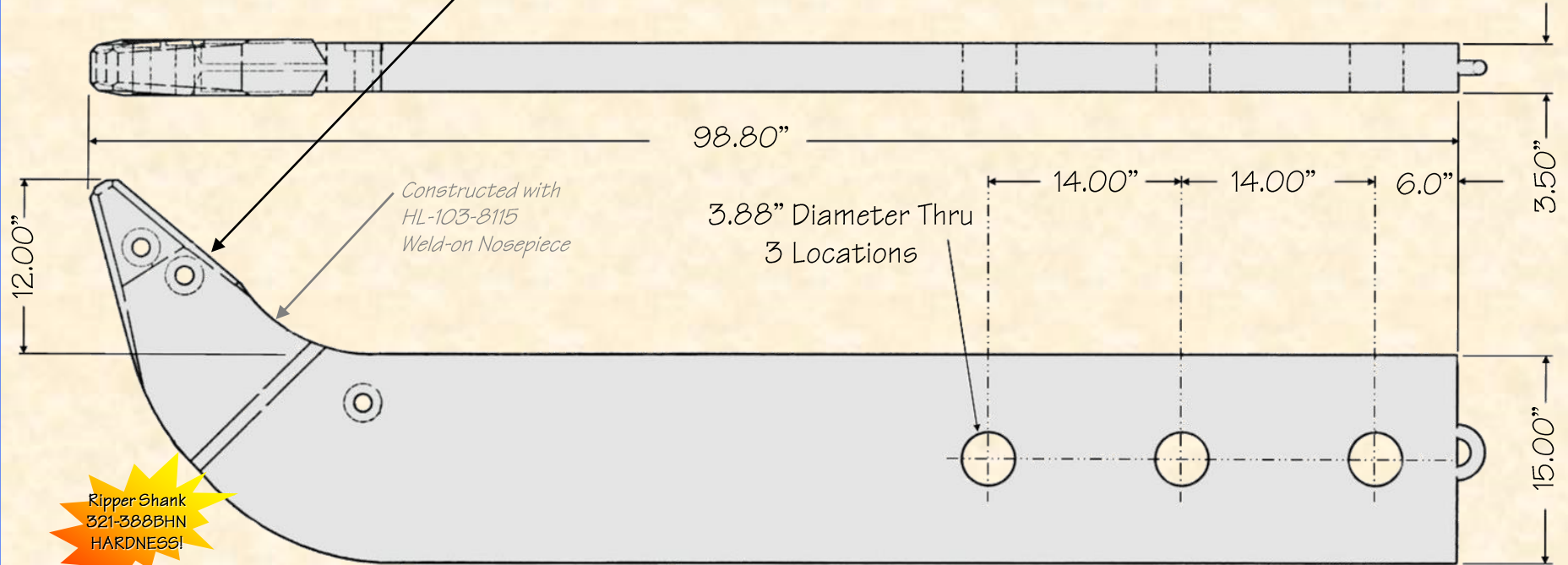

ORIGINAL PRODUCT

**H&L<sup>®</sup> TOOTH COMPANY**

Factory Direct Made in Tulsa, Oklahoma

**HL-8E-8411**

Ripper Shank

1420.0#/1644.11kgs.

*H&L Tooth Company History since 1931:*

*This H&L's Cat style HL-8E-8411 ripping shank is a replacement for Caterpillar's Model D10N, replaces part number 8E-8411. This shank uses the H&L's R-500 Series tooth system. Ripper shank was engineered and introduced by the H&L Tooth Company in 1997.*

*H&L products meet or exceeds all OEM standards.*