

R090.2016



H&L's Cat Style HL-114-4503 Rippers are produced from Chrom-Moly-Nickel grade alloy steels to enhance shank **DURABILITY and TOUGHNESS!**

© H&L Tooth Company 2016

Uses (R500) HL-4T-4502ST-4R Tooth with HL-6Y-1204 and HL-6Y-1202 Pin and Retainer HL-9W-8365 Wear Plate with two HL-6Y-1204 with HL-6Y-1202 Pins and Retainers

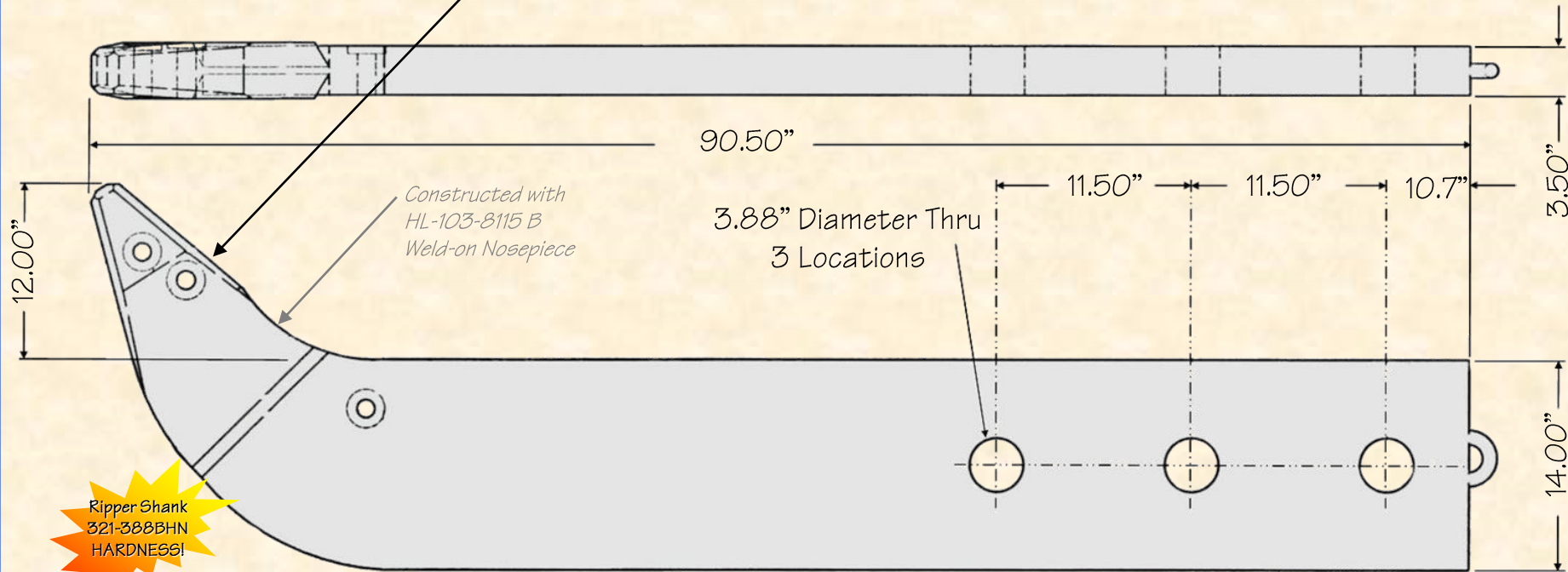

ORIGINAL PRODUCT

H&L® TOOTH COMPANY

Factory Direct Made in Tulsa, Oklahoma

HL-114-4503

Ripper Shank

1285.0#/1583.0kgs.

H&L Tooth Company History since 1931:

This H&L's Cat style HL-114-4503 ripping shank is a replacement for Caterpillar's Model D9R Dozers. This shank uses the H&L's R-500 Series tooth system. Ripper shank was engineered and introduced by the H&L Tooth Company in 2003.

H&L products meet or exceeds all OEM standards.