

T252.2019

QUALITY
since 1931

© H&L Tooth Company 2019

H&L's 251-112-20 loader Adapters are produced from aircraft quality Chrom-Moly-Nickel grade alloy steels to enhance adapter **DURABILITY** and **TOUGHNESS!**

388-415BHN
HARDNESS!

ORIGINAL PRODUCT

H&L® TOOTH COMPANY

Factory Direct Made in Tulsa, Oklahoma

The "OEM" Flexpin Style **LOADER ADAPTER** design

251-112-20

Loader Adapter
10.0#/4.54kgs.

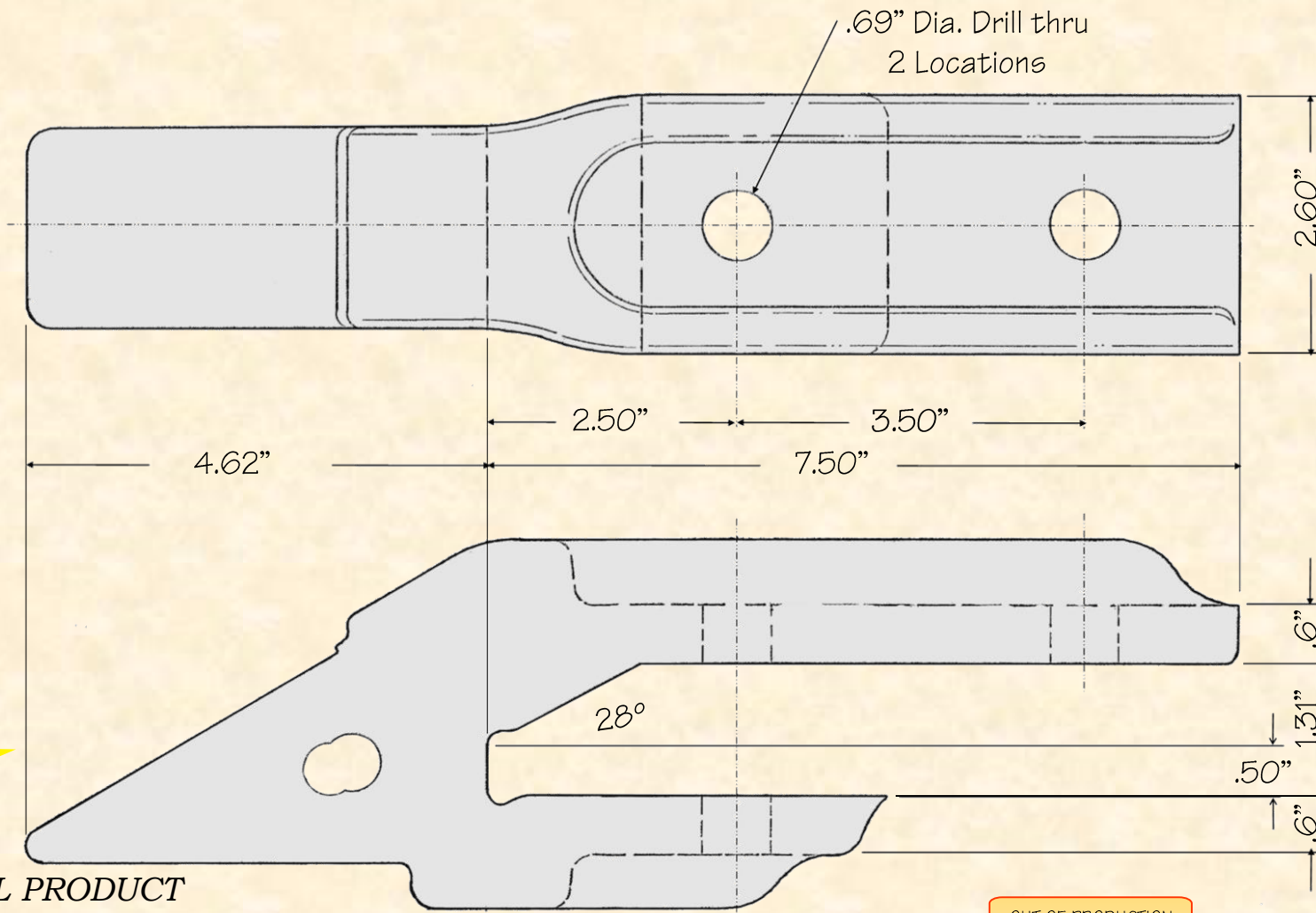

OUT OF PRODUCTION

37

REMAIN IN STOCK

H&L Tooth Company History since 1931:

This One and One Half Leg bolt-on loader adapter was first designed and introduced by H&L Tooth Company for the J. I. Case Company, Model W-24D in 1982. Other Case numbers L104555, L110505 and L891273 The OEM 251-112-20 part number is also a replacement for H&L's Dealer #L-4254-25 adapter.