

*H&L Tooth Company  
Quality GET  
since 1931!*

# DRS 201RE5

## DeltaWing

### Lip Saver Teeth! RhombicGETsystem®



#### Unique Diagonal Retention System

- ✓ Diagonal Flexpin® Retention Connection
- ✓ Increases bucket penetration!
- ✓ Increase bucket CAPACITY!
- ✓ Increases the life of the bucket lip edge!
- ✓ Reduces expensive bucket lip maintenance!

©H&L Tooth Company 2020

*DRS style Weld-on assembly... the most important part of you working backhoe!*

*Diagonal Retention System with a unique 45° degree installation and removal!*



Flexpin® hardware allows for installation and removal, with **NO** minimum space requirement!

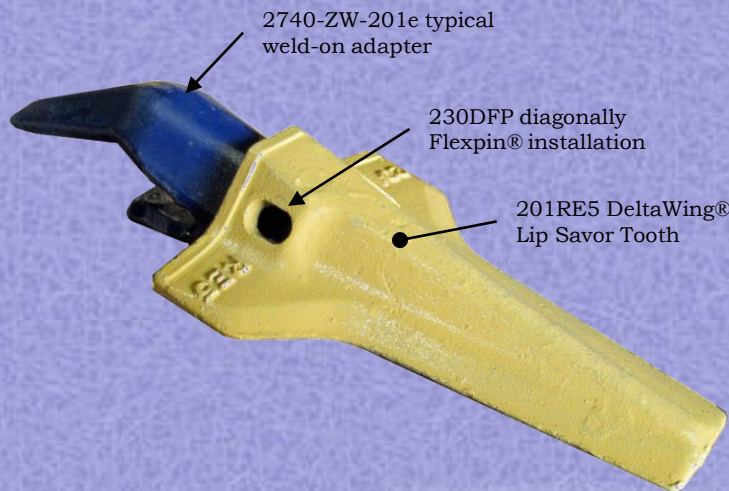

#### DRS style Weld-on adapter

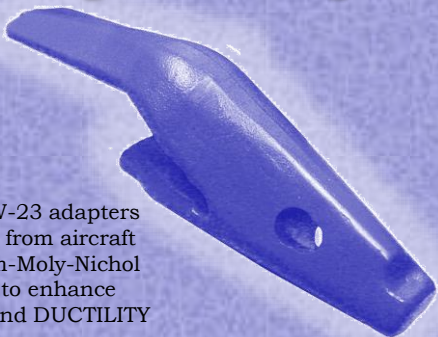

H&L 2740-ZW-23 adapters are produced from aircraft quality Chrom-Moly-Nichol grade alloy to enhance **DURABILITY** and **DUCTILITY**

#### 201RE5 DeltaWing Tooth

4.00 lbs.

Winged teeth protect the cutting edge from wear!

Unsurpassed bucket penetration, lip edge stays sharp while protecting the bucket edge!



#### 2740-ZW-201RE5 Assembly

7.50 lbs.

**Manufactured under multiple United States and foreign patents!**

All H&L products **WARRANTED** against premature breakage!

**www.hltooth.com • 1-800 HL TOOTH**  
(1-800-458-6684)

## 230DFP Attachment Hardware

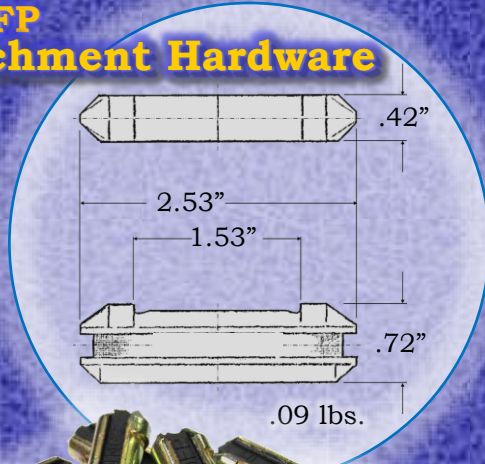

## Stays Sharp the life of the tooth!

- ✓ Reduces Lip scalloping between the teeth!
- ✓ Increases bucket productivity!
- ✓ Guaranteed against premature breakage!
- ✓ Every tooth change out supply's your used bucket with a NEW leading edge!

## •Fits all Bucket using the 201 e-series tooth system!

The Rhombic**GET**system design *REDIRECTS* the adapter and tooth material to the vertical plane; resulting in *GREATER STRENGTH* in the direction in which the bucket loads!

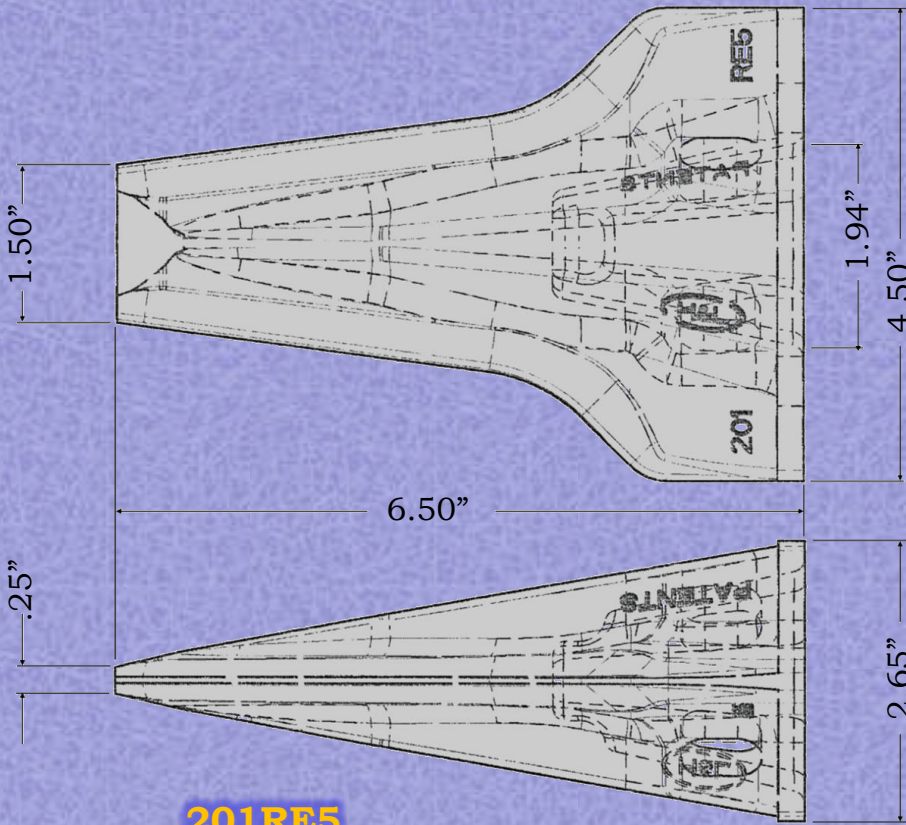

## 201RE5

3.40 lbs.

H&L 201RE5 DeltaWing® teeth are produced from aircraft quality Chrom-Moly-Nichel grade alloy to enhance DURABILITY and DUCTILITY

## •Backhoe Conversion and Lip Repairs!

For 12", 18", 24" and 36" Wide Buckets



## Typical Dimensional Layout

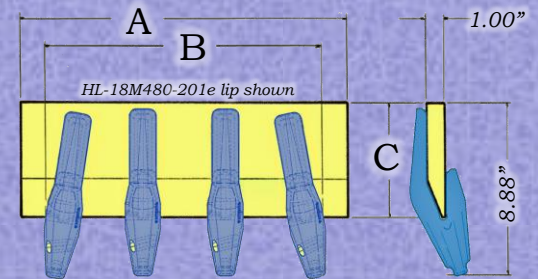

H&L Part #	Width	A	B	C
HL-12M480-20le	12.00"	12.62"	10.69"	6.00"
HL-18M480-20le	18.00"	18.50"	16.12"	6.00"
HL-24M480-20le	24.00"	24.50"	22.31"	6.00"
HL-36M480-20le	36.00"	36.00"	33.75"	8.00"

For greater detail and information on Repair Lip and hardware please review H&L Flyer 236.2020

**Manufactured under multiple United States and foreign patents!**

All H&L products WARRANTED against premature breakage!

**www.hltooth.com • 1-800 HL TOOTH**  
(1-800-458-6684)