

H&L Tooth Company  
Quality **GET** since 1931

#209.2024 Catalog  
A ISO 9001 CERTIFIED Company



# Tooth Company Ground Engaging Tools

## H&L® ORIGINAL OEM Wear Parts

Designed and Produced for:

•Cat® •Case® •Deere® •JCB® •New Holland® and Others

[www.hltooth.com](http://www.hltooth.com)

**Forged Original  
230SP  
since  
1957**



**Top Pin  
233SP  
Tooth**



*233 Kliploc® Series*

**Forged  
201RE2D  
Tooth**



*RhombicGETsystems®*

**Quality  
GET since  
1931**

**Triple Tiger®  
for  
all  
23  
Series  
Adapters**



**H&L® Style  
Flexpin®**



**H&L® Original  
Trencher  
Tap-On  
Style  
Teeth**



**230 and 201 Lip  
Conversion**



**H&L®  
Original  
Forged  
and  
Cast  
STAR 230ST**



**H&L®  
1 3/4SP  
Style  
Scarifiers**



**The Original  
Fabricated  
Style  
Teeth**



**Original  
H&L®  
Scarifier  
and  
Rippers**



**DeltaWing®  
Patented  
Lip Saver  
23  
Series  
Teeth**



**H&L®  
Backhoe  
and  
Excavator  
Buckets**



**Bolt-On  
Style  
Adapters**



**H&L®  
Backhoe  
and  
Back-Up  
Rippers**



# 1-800-HL TOOTH

®Is a registered trademark of the respectively named Company.  
All manufacturer's names, numbers, symbols and descriptions are used for reference purposes only.

# Home of the H&L Tooth Company, Tulsa Oklahoma



200,000 square foot  
manufacturing facility for  
**QUALITY FORGED WEAR PARTS**  
©H&L Tooth Company 2024

1-800-HL TOOTH (1-800-458-6684) • Visit us at [www.hltooth.com](http://www.hltooth.com)



## Page #

## Product Index

3

The Original **FORGED 230 Series Tooth System**.  
Tooth styles SP, ST, CLAW, T, T9, TT and CTT.

4

The Original **Value-CAST 230 Series Line-up**. Tooth Styles  
CSP, CST, TF, TR3, THD, TW, CF, CFC, CHF and CHFC.

5

**230 Series Patented DeltaWing® Lip Saver Tooth System**, SP-5, HD-5, T9-5  
and TT7-5. **The Original 23SP Lite Duty Sharp Penetration** since 1931.

6

**230 Series most popular Weld-on and selected Bolt-on Adapters**.  
Bottom strap, wrap around and flush mount styles available.

7

**230 Series Flexpin®** attaching Hardware... the 23FP, 23DLFP and 230DFP.  
Patented 230 Series B230HL-1 **Pin Caddy® Removal Tool**.

8

**Variety of 230 Series Tooth KITS**

9

230 Patented DeltaWing® Series **LIP SAVER Tooth KITS**.  
H&L's **233 Series Top Pin Kliploc® Hammerless Tooth System**.

10

**H&L® Original CRIMP-ON Series** fabricated OSP, 00SP, 2AH, 3CH  
and 1 3/4SP teeth and adapter systems manufactured since 1941.

11

**24-240 Series** forged and cast Teeth, weld-on and bolt-on  
Adapters with 24FP Flexpin® attaching hardware.

12

**252 Series** forged and cast Teeth with weld-on and bolt-on  
Adapters with 25-26FP Flexpin® attaching hardware.

13

**272 Series** forged and cast Teeth with 20-27FP Flexpin® attaching hardware.  
**20 and 31 Series** forged Teeth, adapters with Flexpin® attaching hardware.

14

**32 and 33 Series** forged Teeth, adapters with Flexpin® attaching hardware.  
**RhombicGETsystems® DRS style Teeth**, weld-on and bolt-on adapters with Flexpin® hardware.

15

**Bucket Lip Conversion** utilizing H&L original 230 side pin or 201 DRS (diagonal pin) Teeth.  
Backhoe Buckets... all Makes and Model. Butt-Weld repair or conversion **Nose Pieces**.

16

**H&L® Scarifiers and Small Rippers** using H&L original designed OSP, 21SP, 1 3/4SP,  
230ST, 240ST, 252ST, 18SP and 19ST Series teeth with Flexpin® attaching hardware.

17

**H&L® Style Rippers**. 36LST Series for Cat, Fiat-Allis, International-Harvester, Komatsu and  
Others by Model Numbers with ripper box sizes. Including Teeth, Flexpin® and Wear Protector.

18

**H&L® Style Rippers**. 38LST Series for Cat, Fiat-Allis, International-Harvester, Komatsu and  
Others by Model Numbers with ripper box sizes. Including Teeth, Flexpin® and Wear Protector.

19

**H&L® Ripper Repair and Conversion Nosepieces**.  
**H&L® Back-Up Ripper Assemblies** for all dozers equipment.

20

**H&L® Backhoe and Excavator style Ripper Box Assemblies**.  
H&L® Original **11-Series and 12-Series** tap-on trencher Teeth and weld-on pockets.

21-22

**H&L® "VP" Vertical, Teeth and Adapters**. Original series from the 1980s...  
195, 205, 315, 325 and 335 series teeth, adapters with attaching Flexpins®.

23

**H&L® Pavement Breakers & Asphalt Cutters**. H&L Allied Equipment for Blades on hydraulic  
asphalt cutters and pavement breakers for Arrow Mfg. and Ottawa Hydra-Hammers



®Is a registered trademark of the respectively named Company.

All manufacturer's names, numbers, symbols and descriptions are used for reference purposes only.

# 230 Series Backhoe Teeth

230 Series, the Most Popular  
Tooth in the World!



## Forged 230 Series Line-up!

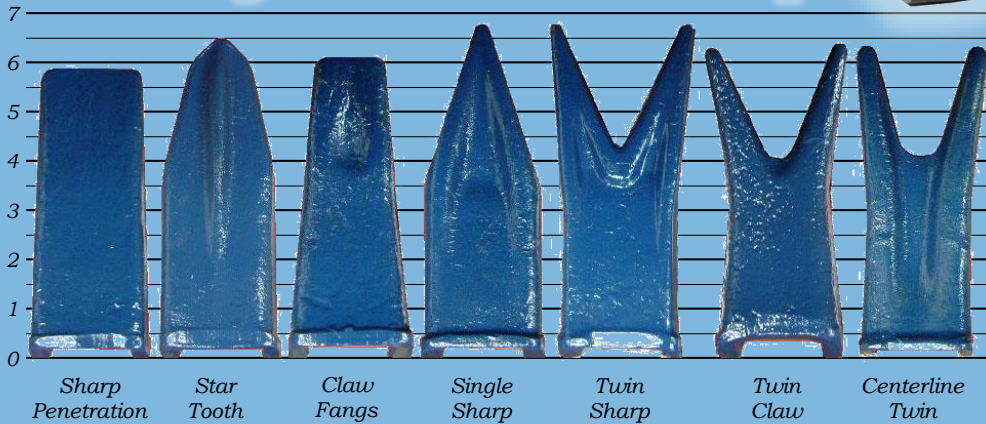

**STILL  
FORGED IN  
THE USA!**

Manufactured  
Under Original  
H&L® Patent  
Specifications!

**230SP** Uses 23FP  
2.6#

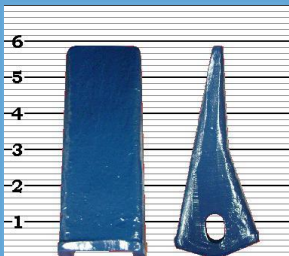

### Sharp Penetration

- Uniforged® from tough Chrom-Moly aircraft grade steels.
- Hardened and tempered for optimum ductility!

**230ST** Uses 23FP  
2.8#



### Star Ripping Design

- Self-Sharpening Star design.
- Uniforged® from tough Chrom-Moly aircraft grade steels.

**230T9** Uses 23FP  
2.5#

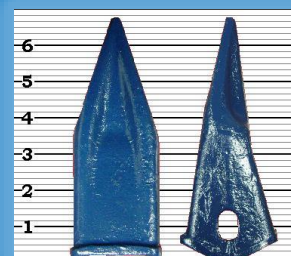

### Single Sharp Design

- 20% Heavier than Competitor Dura casting!
- Uniforged® for exceptional strength.

**230T** Uses 23FP  
2.7#

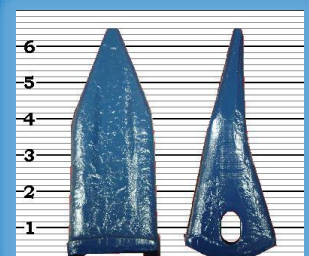

### Single Sharp Design

- Uniforged® from tough Chrom-Moly aircraft grade steels.

**230TT7** Uses 23FP  
3.2#

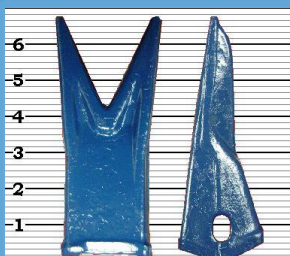

### Twin Sharp Design

- 20% Heavier than Competitor Dura casting!
- Uniforged® for exceptional strength.

**230CTT** Uses 23FP  
2.8#

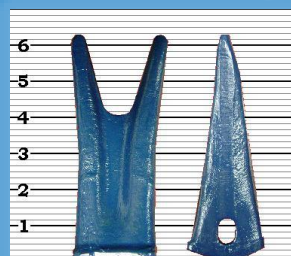

### Centerline Twin Design

- Heavier tines enhances reliability and greater strength.

**230TTCLAW** Uses 23ODFP  
3.2#

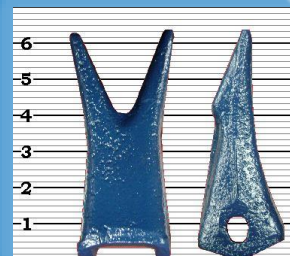

### Twin Fangs Design

- "A unique curved design that lets the bucket dig with 23% less effort". The CLAW'S aggressive digging action delivers faster cycles and better bucket fill!

**230CLAW** Uses 23ODFP  
2.9#

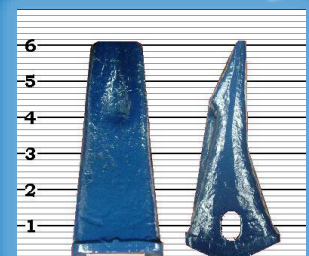

### Claw Fangs Design

- "A unique curved design that lets the bucket dig with 23% less effort". The CLAW'S aggressive digging action delivers faster cycles and better bucket fill!

®Is a registered trademark of the respectively named Company. All manufacturer's names, numbers, symbols and descriptions are used for reference purposes only.

[www.hltooth.com](http://www.hltooth.com)

# 230 Series Backhoe Teeth

## Value-Cast 230 Series Line-up!



©H&L Tooth Company 2024

**230CSP** 2.7#

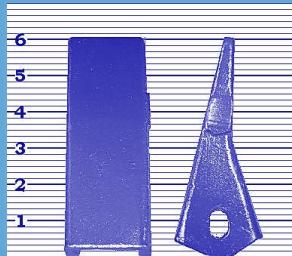

**Cast Sharp Penetration** Uses 23FP

●H&L® Factory Inspected for QUALITY.

**230CST** 2.6#

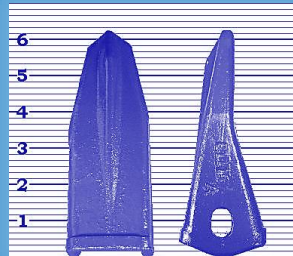

**Cast Star Ripping Design** Uses 23FP

●H&L® Factory Inspected for QUALITY.

**230TF** 3.9#

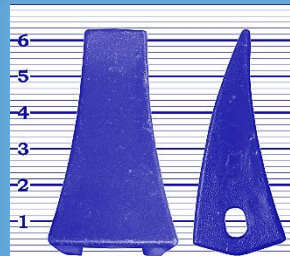

**Cast Fangs TF23D Design** Uses 23ODFP

●H&L® Factory Inspected for QUALITY.

**230CPE** 2.6#

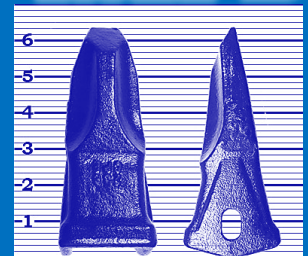

**Cast Rock Penetrator Design** Uses 23ODFP

●H&L® Factory Inspected for QUALITY.

**230THD** 3.1#

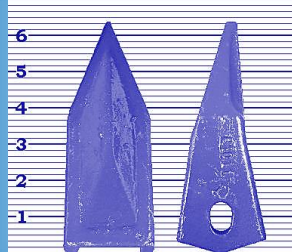

**Cast Single Sharp Design** Uses 23FP

●H&L® Factory Inspected for QUALITY.

**230TL** 2.1#

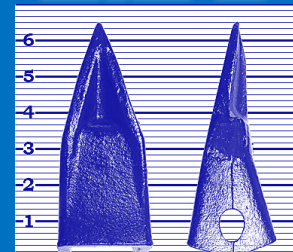

**Cast Long Single Sharp Design** Uses 23FP

●H&L® Factory Inspected for QUALITY.

**230TW** 3.9#

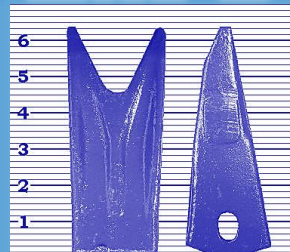

**Cast Twin Sharp Design** Uses 23FP

●H&L® Factory Inspected for QUALITY.

**230WTL** 2.4#

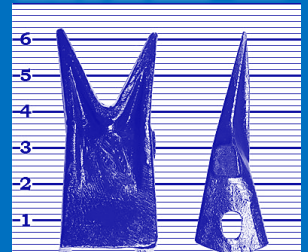

**Cast Long Twin Sharp Design** Uses 23FP

●H&L® Factory Inspected for QUALITY.

**230TR3** 4.5#



**Patented Triple Tiger® Design** Uses 23ODFP

●H&L® Factory Inspected for QUALITY.

**230CF** 3.5#

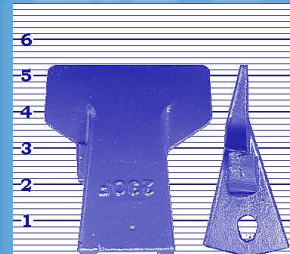

**Cast Flared Tooth** Uses 23FP

●H&L® Factory Inspected for QUALITY.

**230CHF** 4.0#

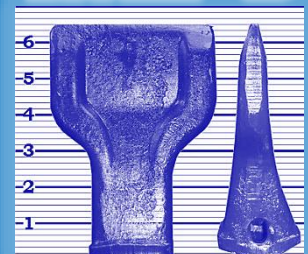

**Cast Heavy Duty Flared** Uses 23ODFP

●H&L® Factory Inspected for QUALITY.



### WARRANTY

All H&L® Value-Cast products are factory inspected and covered under H&L's standard warranty program.



®Is a registered trademark of the respectively named Company.

All manufacturer's names, numbers, symbols and descriptions are used for reference purposes only.

# 230 Series DeltaWing® Lip Saving Teeth

**DeltaWing™ teeth**

- Wear Protection!
- Greater Penetration
- Increased Bucket Capacity!



*Stays SHARP while protecting the LIP!*

## H&L® Patented Lip Saver Tooth Systems!

*Fits all 23-230 series field adapters!  
Stops Flexpin® walking with a patented second lock in the tooth!*

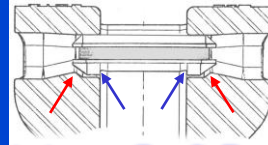

*Protects your Case®, Deere®, DitchWitch®, JCB®, New Holland® and other buckets.*



*Increased bucket capacity!*

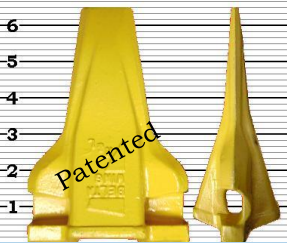

*No more lip wear scalloping!*

<p><b>230SP-5</b> 3.2#</p>  <p><i>Sharp Penetration Lip Saver Teeth</i> Uses 230DFP</p> <ul style="list-style-type: none"> <li>•H&amp;L® Factory Inspected for QUALITY.</li> <li>•Patented secondary lock</li> </ul>	<p><b>230HD-5</b> 3.8#</p>  <p><i>Heavy Duty Lip Saver Teeth</i> Uses 230DFP</p> <ul style="list-style-type: none"> <li>•H&amp;L® Factory Inspected for QUALITY.</li> <li>•Patented secondary lock</li> </ul>	<p><b>230T9-5</b> 3.5#</p>  <p><i>Single Tiger Lip Saver Teeth</i> Uses 230DFP</p> <ul style="list-style-type: none"> <li>•H&amp;L® Factory Inspected for QUALITY.</li> <li>•Patented secondary lock</li> </ul>	<p><b>230TT7-5</b> 4.7#</p>  <p><i>Twin Tiger Lip Saver Teeth</i> Uses 230DFP</p> <ul style="list-style-type: none"> <li>•H&amp;L® Factory Inspected for QUALITY.</li> <li>•Patented secondary lock</li> </ul>
--	---	--	--

All H&L Products are WARRANTED against premature breakage!

# “23SP” Sharp Penetration Tooth

## H&L's Original Lite Duty Digging Tooth!

*Still manufactured under original H&L® patent specifications since 1931!*

**23SP**  
2.1#



*Sharp Penetration cast Tooth uses the Original 23FP Flexpin®*



**1-800-HL TOOTH**

®Is a registered trademark of the respectively named Company.  
All manufacturer's names, numbers, symbols and descriptions are used for reference purposes only.

# 23/230 Series Weld-On & Bolt-On Adapters

©H&L Tooth Company 2024

## WELD-ON Mini Excavator Bottom Mount "1CW" Adapters

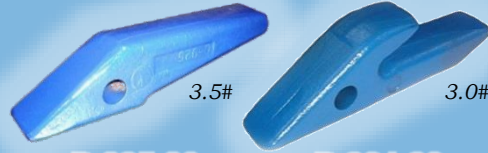

**D-925-23**  
Up to 1.00" Lip

**D-834-23**  
Up to 1.00" Lip

## WELD-ON Tooth Bar Style "1W" Adapter



**2740-AJW-23**  
1.56" Opening



## OEM WELD-ON Backhoe Wrap Around "1W" Adapters

"Deep Dig" Center

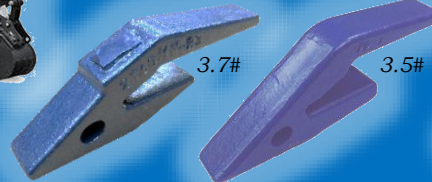

**2740-MW-23**  
0.62" to 0.88" Lip

**2740-AW-23**  
0.62" to 0.88" Lip

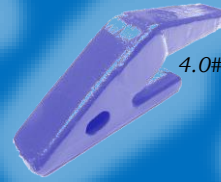

**2740-W-23**  
1.00" Lip

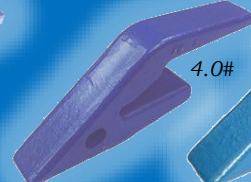

**2740-ZW-23**  
1.00" Lip

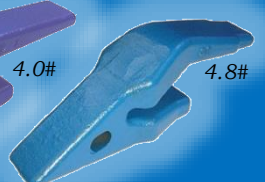

**2740-AFW-23**  
1.00" Lip

Case Style "Deep Dig" Center and Corner

## WELD-ON Top Mount "1BW" Adapters



**L-4107-AJW-23**  
0.50" Lip

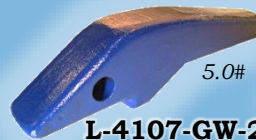

**L-4107-GW-23**  
0.75" Lip

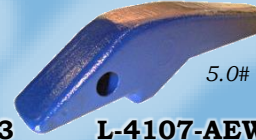

**L-4107-AEW-23**  
0.88" Lip



**L-4107-ARW-23**  
1.00" Lip



**HL-1001-23**  
.75" Lip



**Bolt-on  
HL-6737324-23**  
0.75" to 1.00" Lip

## WELD-ON REPAIR Nose Piece



1.74#

**230WN  
Nosepiece**

## MOST POPULAR BOLT-ON "1" Style Loader Adapters

H&L has designed many hundreds of Loader Adapters over the last nine decades. Give us a call with your specific dimensions.



**Typical Adapter  
"1" Style**



**L-3445 series  
Adapter "1" Style**



**L-3445-D-23 Adapter  
"1A" Style**

### Dimensional Review

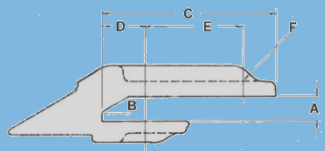

#1 Bolt-on Style Adapter

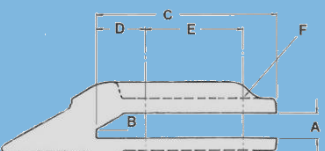

#1A Bolt-on Style Adapter

Adapter #	WT.	A	B	C	D	E	F	Style
<b>L-4139-A-23</b>	7.0#	0.50"	45°	6.25"	1.25"	3.00"	0.69"	1
<b>L-3445-A-23</b>	6.3#	0.62"	23°	5.88"	1.75"	3.00"	0.69"	1
<b>L-4006-23</b>	6.0#	0.75"	30°	6.25"	1.75"	3.00"	0.56"	1
<b>L-4031-23</b>	6.0#	0.75"	25°	6.50"	2.00"	3.00"	0.69"	1
<b>L-3445-23</b>	5.5#	0.75"	23°	6.50"	2.25"	3.00"	0.69"	1
<b>L-3445-D-23</b>	10.5#	0.75"	23°	6.12"	2.25"	3.00"	0.69"	1A
<b>L-4193-23</b>	5.0#	1.00"	30°	6.50"	2.00"	3.25"	0.69"	1
<b>L-4275-23</b>	5.0#	1.00"	23°	5.62"	2.44"	2.00"	0.56"	1

[www.hltooth.com](http://www.hltooth.com)

® is a registered trademark of the respectively named Company.

All manufacturer's names, numbers, symbols and descriptions are used for reference purposes only.

# 23/230 Series Flexpins®

©H&L Tooth Company 2024

## The Original 23FP Flexpin®

All Series Flexpins are built with sharp ends to ease installation!

BACK Halves of Flexpin® towards Bucket

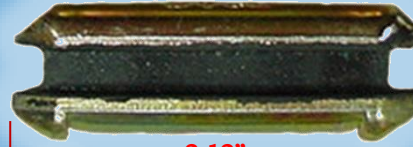

Art work published in 1952

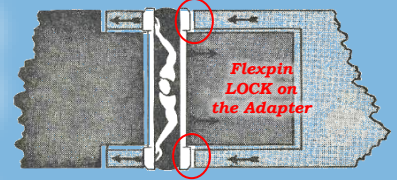

The H&L Flexpin® consists of two half-round lengths of steel with a section of live rubber vulcanized between to form an oval shaped pin. The compressed rubber forces the Flexpin® half-round sections in opposite directions. One half-round section bears on the nosepiece and the other bears only at each side of the tooth point to hold it securely on the adapter. See webpage for all Flexpin® updates and dimensions T163.2016.

## 23DLFP Dual Lock Flexpin®

More locking powers for worn adapter installations!

## 230DFP DeltaWing Flexpin®

Ideal for Fangs, Triple Tiger® and Deltawing® teeth or worn assemblies requiring **LONGER** pins!

# 230 SERIES PIN CADDY®

## Installation and Remover Tool

### B23HL1 Patented Tool for ALL 230-Series Teeth

Consists of  
1-B23HL Tool  
5-23FP Flexpins



Flexpin®  
Installation



Pin Caddy®  
Holds a  
Complete Set  
of Flexpins®



**REMOVE IT  
FASTER!**



Flexpin®  
Removal

**FREE Flexpins**



United States and foreign Patents

**1-800-HL TOOTH**

# 230 Series Tooth KITS

©H&L Tooth Company 2024

**KIT230SP** 18.0#

FORGED in the USA!

Consists of 5-230SP, 5-23FP Flexpins & 1-23RT

**KIT230ST** 19.0#

FORGED in the USA!

Consists of 5-230ST, 5-23FP Flexpins & 1-23RT

**KIT230CTT** 19.0#

FORGED in the USA!

Consists of 5-230CTT, 5-23FP Flexpins & 1-23RT

**KIT230CLAW** 19.5#

FORGED in the USA!

Consists of 5-230CLAW, 5-230DFP Flexpins & 1-23RT

**STILL FORGED IN THE USA!**

**“Cast-Value” Produced to H&Ls High Standards for QUALITY!**

**KIT230T9** 18.0#

FORGED in the USA!

Consists of 5-230T9, 5-23FP Flexpins & 1-23RT

**KIT230TT7** 20.0#

FORGED in the USA!

Consists of 5-230TT7, 5-23FP Flexpins & 1-23RT

**KIT230TTCLAW** 19.0#

FORGED in the USA!

Consists of 5-230TTCLAW, 5-230DFP Flexpins & 1-23RT

**KIT230CSP** 18.0#

Consists of 5-230CSP, 5-23FP Flexpins & 1-23RT

**KIT230CST** 18.0#

Consists of 5-230CST, 5-23FP Flexpins & 1-23RT

**KIT230TW** 21.5#

Consists of 5-230TW, 5-23FP Flexpins & 1-23RT

**KIT230TF** 21.5#

Consists of 5-230TF, 5-230DFP Flexpins & 1-23RT

**KIT230THD** 19.0#

Consists of 5-230THD, 5-23FP Flexpins & 1-23RT

**KIT230CF** 21.5#

Consists of 5-230CF, 5-23FP Flexpins & 1-23RT

**KIT230CHF** 22.0#

Consists of 5-230CHF, 5-230DFP Flexpins & 1-23RT

**KIT230TR3** 24.0#

Patented

Consists of 5-230TR3, 5-230DFP Flexpins & 1-23RT

**The most popular tooth in the World!**

[www.hltooth.com](http://www.hltooth.com)



# DeltaWing® TOOTH KITS

©H&L Tooth Company 2024

## H&L® Patented Lip Saver Tooth Systems!

**KIT230HD-5** 21.5#



Consists of 5-230HD5, 5-230DFP Flexpins & 1-23RT

**KIT230SP-5** 19.0#



Consists of 5-230SP-5, 5-230DFP Flexpins & 1-23RT

**KIT230TT7-5** 24.0#



Consists of 5-230TT7-5, 5-230DFP Flexpins & 1-23RT

**KIT230T9-5** 21.5#



Consists of 5-230T9-5, 5-230DFP Flexpins & 1-23RT

Protects your Case®, Deere®, DitchWitch®, JCB®, New Holland® and other buckets utilizing 230-Series Teeth.

## 233 Series Top Pinning Kliploc®

Hammerless 233  
an easy Top  
Locking System

Direct Replacement for  
Flexpin Style Teeth

Magically Converts Sidepin to Top Pin!



Only from the H&L Tooth Company, GET since 1931



ISO 9001 CERTIFIED Company

Fits All Existing 230 Series Adapters!

Search 233 on H&L webpage!



**KIT233SP** 22.0#



Consists of 5-233SP, 5-233CLP, 5-233Inserts

**KIT233T9** 19.1#



Consists of 5-233T9, 5-233CLP, 5-233Inserts

**KIT233TT7** 21.6#



Consists of 5-233TT7, 5-233CLP, 5-233Inserts

**Fits Your Existing  
BACKHOE  
SHANKS!**

Case®, Deere®, JCB® and  
Other Backhoe Shanks!

Please ask Customer Service  
to supply Punch at  
NO CHARGE when ordering!

No more "pin walking"  
No more difficult side pin removal!  
No more special installation tools!  
No more front/back issues!

**KIT233TF** 26.0#



Consists of 5-233TF, 5-233CLP, 5-233Inserts

**KIT233TR3** 26.0#



Consists of 5-233TR3, 5-233CLP, 5-233Inserts

**KIT233F** 26.0#



Consists of 5-233F, 5-233CLP, 5-233Inserts



No more  
smashed finger  
injuries!

Manufactured under  
United States and foreign Patents

1-800-HL TOOTH

# Fabricated CRIMP-ON Series Teeth and Adapters

©H&L Tooth Company 2024

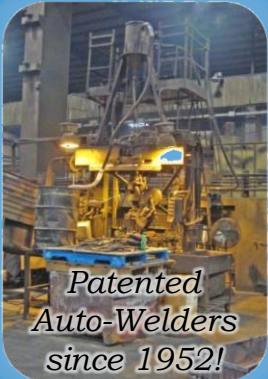

Patented Auto-Welders since 1952!

## “OSP” Crimp-on Tooth System

**OSP**  
0.3#

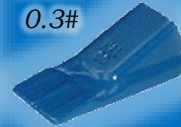

Sharp Penetration  
Fabricated Teeth

D-838-0  
Adapter  
0.5#

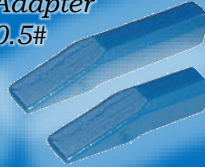

D-836-0  
Adapter  
0.4#

G-669-0  
Scarifier  
1.1#



## “OOSP” Crimp-on Tooth System

**OOSP**  
0.5#

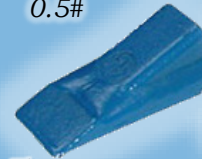

Sharp Penetration  
Fabricated Teeth



2898-W-00  
Adapter  
1.0#

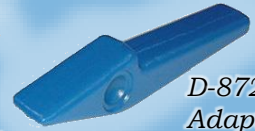

D-872-00  
Adapter  
1.1#

## “2AH” Tooth and Adapter Crimp-on Style System

Designed and  
Manufactured  
since 1946!

**2AH**  
0.9#



Sharp Penetration  
Fabricated Teeth



D-835-2A Adapter  
2.0#

H&L Pin-on “2B”  
Adapters Available



D-862-2A Adapter  
1.6#

H&L Pin-on “2B”  
Adapters Available



L-2520-BW-2A Adapter  
1.9#

H&L Pin-on “2B”  
Adapters Available

## “3CH” Tooth and Adapter Crimp-on Style System

Designed and  
Manufactured  
since 1944!

**3CHLR**  
1.8#



Sharp Penetration  
Fabricated Teeth

Limited Quantity Available

**3CHW**  
2.4#



Wide Flared  
Fabricated Teeth



D-834-3C Adapter  
3.0#

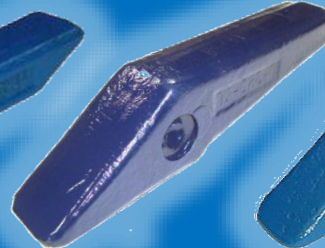

D-925-3C Adapter  
3.5#



2740-JW-3C Adapter  
3.0#



**HL-8075SP**  
1.03#  
Crimp-on or Pin-on



**1 3/4SP**  
1.03#  
Crimp-on Only

Sharp Penetration Fabricated Teeth

H&L® Tooth offers a variety of  
scarifiers, search our webpage  
or call Customer Service.



G-163-BW-3/4 Shank  
8.0#

G-163-HW-3/4 Shank  
7.8#

G-163-CD-3/4 Shank  
7.6#

## “1 3/4SP” & HL-8075SP Tooth and Scarifier System

# 240 Series Teeth, Adapters and Flexpin®

©H&L Tooth Company 2024

## 24 and 240 Series Teeth



### Backhoe WELD-ON "1CW" & "1W" Adapters



### The Original 24FP Flexpin®

All Series Flexpins are built with sharp ends to ease installation!



The H&L® Flexpin® consists of two half-round lengths of steel with a section of live rubber vulcanized between to form an oval shaped pin. The compressed rubber forces the Flexpin® half-round sections in opposite directions. See webpage for all Flexpin® specifications and dimensions T163.2016.

## MOST POPULAR 24-240 Series BOLT-ON Adapters

H&L Tooth offers a variety of 240 series adapters. Search our webpage or call Customer Service. Older OEM Style Adapters



### Dimensional Review

H&L® has designed many hundreds of Loader Adapters over the last eight decades for many OEM. Give us a call with your specific dimensions.

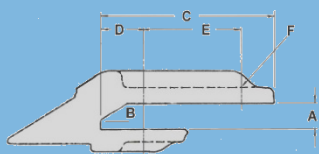

Typical Dimensions

Adapter #	WT.	A	B	C	D	E	F	Style
L-3445-D-24	6.5#	0.75"	23°	6.12"	2.25"	3.00"	0.69"	#3445
L-4252-24	9.0#	0.75"	22°	7.60"	2.48"	4.33"	0.81"	#1
L-3679-A-24	15.0#	1.00"	23°	7.75"	2.78"	3.75"	0.81"	#3679
L-3679-24	18.0#	1.00"	23°	7.85"	2.85"	3.75"	0.81"	#1A-COR
L-4108-BF-24	7.5#	1.00"	23°	7.00"	2.46"	3.50"	0.69"	#1B
L-4191-24	9.0#	1.00"	30°	7.62"	2.00"	4.62"	0.69"	#1
L-4128-24	8.5#	1.00"	30°	7.25"	2.50"	3.50"	0.69"	#1
L-4202-24	8.5#	1.25"	30°	7.25"	2.50"	3.50"	0.69"	#1
L-2021F-24	10.5#	1.25"	25°	7.38"	3.38"	3.00"	0.69"	#2021

®Is a registered trademark of the respectively named Company.

All manufacturer's names, numbers, symbols and descriptions are used for reference purposes only.

# 252 Series Teeth, Adapters and Flexpin®

©H&L Tooth Company 2024

## 252 Series Teeth



**Backhoe  
WELD-ON  
"1CW" & "1W"  
Adapters**



**H&L® 25-26FP  
Flexpin®**

*All Series Flexpins are built with sharp ends to ease installation!*



The H&L® Flexpin® consists of two half-round lengths of steel with a section of live rubber vulcanized between to form an oval shaped pin. The compressed rubber forces the Flexpin® half-round sections in opposite directions. See webpage for all Flexpin specification and dimensions T163.2016.



**H&L Tooth offers a variety of 252 series adapters. Search our webpage or call Customer Service.**

## MOST POPULAR BOLT-ON Adapters

*Older OEM Style Adapters*



Adapter #	WT.	A	B	C	D	E	F	Style
L-3637-A-25	25.5#	1.00"	23°	7.75"	2.78"	3.75"	0.81"	#3679
L-3637-25	20.0#	1.00"	23°	7.75"	2.78"	3.75"	0.81"	#1A-COR
L-3679-A-25	25.0#	1.00"	23°	7.75"	2.78"	3.75"	1.06"	#3679
L-3679-25	20.0#	1.00"	23°	7.75"	2.78"	3.75"	1.06"	#1A-COR
L-4052-25	12.0#	1.00"	30°	8.25"	2.12"	3.62"	0.69"	#1
L-4272-A-25	16.0#	1.25"	28°	7.25"	2.53"	3.50"	0.81"	#4272
L-3623-B-25	16.0#	1.25"	30°	7.00"	2.50"	3.50"	0.81"	#1A-COR
L-4279-25	25.0#	1.25"	30°	8.88"	3.50"	4.00"	0.81"	#1A
L-4194-25	10.0#	1.38"	23°	8.38"	3.38"	4.00"	0.81"	#1

### Dimensional Review

H&L® has designed many hundreds of Loader Adapters over the last eight decades for many OEM. Give us a call with your specific dimensions.

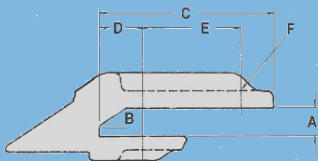

Typical Dimensions

®Is a registered trademark of the respectively named Company.

All manufacturer's names, numbers, symbols and descriptions are used for reference purposes only.

# 272 Series Teeth, Adapters and Flexpin®

## 272 Series Teeth

**272SP**

8.5#



FORGED in the USA!

**272ST**

9.3#



FORGED in the USA!

## Excavator WELD-ON

## “1CW”, “1W” & “1BW” Adapters

**3000-W-27**

1.88” Lip  
13.0#



“1CW” Bottom Mount

**2740-FW-27**

1.50” Lip  
11.0#



“1W” Wrap Around

**L-4095-AW-27**

1.50” Lip  
20.0#

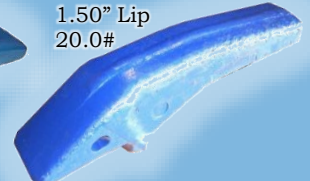

“1BW” Flush Mount

## H&L® 20-27FP Flexpin®

All Series Flexpins are built with sharp ends to ease installation!



The H&L® Flexpin® consists of two half-round lengths of steel with a section of live rubber vulcanized between to form an oval shaped pin. The compressed rubber forces the Flexpin® half-round sections in opposite directions

See webpage for all Flexpin specifications and dimensions T163.2016.



# 20 and 31 Series Teeth, Adapters and Flexpin®

H&L Tooth offers a variety of 20 and 31 series adapters, most are custom and not stocked. Search our webpage or call Customer Service.

H&L® 20 Series Teeth and Weld-On Adapters are made for 1.25” to 1.75” in lip thickness, since 1963.

**20SP**

11.0#

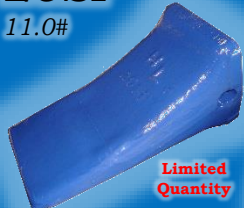

Limited Quantity

Sharp Penetration  
FORGED in the USA!

**20ST**

11.8#

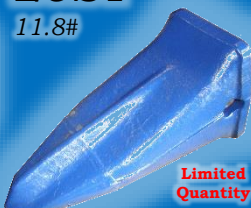

Limited Quantity

Star Tooth  
FORGED in the USA!

**L-4092 Series**

25.0#



“1BW” Flush Mount

**3000-W-20**

18.0#

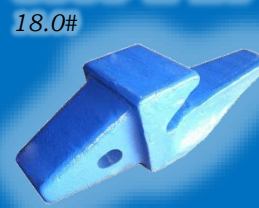

“1CW” Bottom Mount

**20-27FP**



H&L® 31 Series Teeth and Weld-On Adapters are made for 1.50” to 2.25” in lip thickness, since 1966.

**31SP**

20.2#



Limited Quantity

Sharp Penetration  
FORGED in the USA!

**31ST**

21.4#



Limited Quantity

Star Tooth  
FORGED in the USA!

**L-4093 Series**

40.0#



“1BW” Flush Mount

**3000-W-31**

28.0#



“1CW” Bottom Mount

**31FP**



# 1-800-HL TOOTH

®Is a registered trademark of the respectively named Company.

All manufacturer’s names, numbers, symbols and descriptions are used for reference purposes only.



# 32 and 33 Series Teeth, Adapters and Flexpin®

H&L® Tooth offers a variety of 32 and 33 series adapters, most are custom and not stocked. Search our webpage or call Customer Service.

**H&L 32 Series Teeth and Weld-On Adapters are made for 1.75" to 2.50" in lip thickness, since 1963.**

## 32SP

29.6#



Limited Quantity

Sharp Penetration  
FORGED in the USA!

## L-4094 Series

50.0#

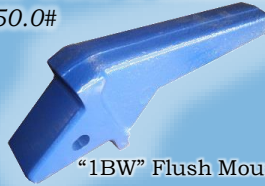

"1BW" Flush Mount

## 3000-W-32

48.0#

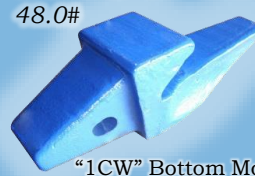

"1CW" Bottom Mount

## 32FP



**H&L® 33 Series Teeth and Weld-On Adapters are made for 2.25" to 3.00" in lip thickness, since 1963.**

## 33SP

43.4#



Limited Quantity

Sharp Penetration  
FORGED in the USA!

## 33H

51.0#



Limited Quantity

Heavy Rock Tooth  
FORGED in the USA!

## L-4173 Series

92.0#



"1BW" Flush Mount

## 3000-W-33

54.0#

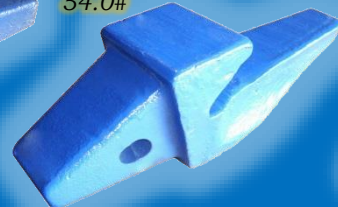

"1CW" Bottom Mount

## 33-35FP



# RhombicGETsystem® - 136, 186 and 201 e-series

Diagonally Pinned Tooth System for Mini-Excavators, Skid-Steers, Backhoes

## 136RE2D

0.8#



## 186RE2D

2.0#



## 201RE2D

3.0#



FORGED in the USA!

## 201RE4

2.8#



FORGED in the USA!

## 201RE9

2.8#



FORGED in the USA!

## 201RE7

2.8#



FORGED in the USA!

RhombicGETsystem® are not interchangeable with Caterpillar® DRS Series Teeth!

## "DRS" Style Weld-On & Bolt-On Adapters for Smaller Mini-Excavator Buckets

Mini-Excavator and Trenchers

### D-835-136e

up to 1.25" Lip

2.0#

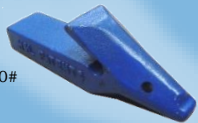

### D-834-186e

up to 1.50" Lip

3.5#



### 136PN

Spiral Pin



### 186PN

Spiral Pin



### L-3761-A-136e

Replaces 138-6410

0.38" Lip



2.0#

### L-3760-A-186e

Replaces 135-9390

0.62" Lip



4.8#

Replacements for Uni-teeth

RhombicGETsystem® are manufactured under multiple United States and foreign PATENTS.

Skid-Steers and Backhoes

### 2740-ZW-201e

1.00" Lip

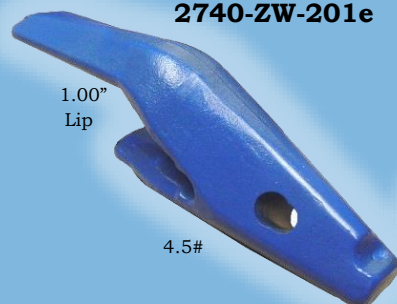

4.5#

### 230DFP

Flexpin®



Not interchangeable with Caterpillar® DRS-200

®Is a registered trademark of the respectively named Company.

All manufacturer's names, numbers, symbols and descriptions are used for reference purposes only.

# BUCKET LIP CONVERSION 230 and 201e-series

©H&L Tooth Company 2024

## Original 230 Series

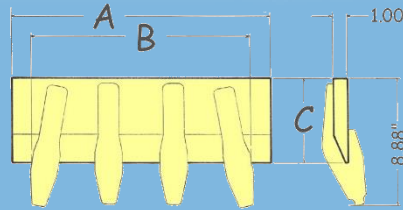

*Lip chart dimensions are for reference purpose only!*

## Rhombic 201e Series



LIP NUMBER	WT.	A	B	C	TOOTH*
HL-12M480-230	32.0#	12.62"	10.69"	6.00"	230SP
HL-12M480-201e	32.0#	12.62"	10.69"	6.00"	201RE2D
HL-18M480-230	44.0#	18.50"	16.12"	6.00"	230SP
HL-18M480-201e	44.0#	18.50"	16.12"	6.00"	201RE2D
HL-24M480-230	59.0#	24.50"	22.31"	6.00"	230SP
HL-24M480-201e	59.0#	24.50"	22.31"	6.00"	201RE2D

*\*Forged Teeth **Made in Tulsa**, Oklahoma, United States of America!*

# BACKHOE BUCKETS from H&L® Tooth!

## Custom Repair Butt-Weld Style



Nosepiece repair  
NP-23B, NP-24B,  
NP-25B, NP-27B,  
NP-18B, NP-19B,  
NP-31B, NP-32B and  
NP-33B Series Teeth.

**Many Makes and  
Models in stock!**

**Unsurpassed Performance  
and Reliability!**

*All bucket widths available  
for Caterpillar®, Case®,  
Deere®, JCB®, Komatsu®,  
New Holland®  
and other backhoe machines!*

**FACTORY WARRANTY!**



## EXCAVATOR BUCKETS

*All Makes,  
Models and Sizes*

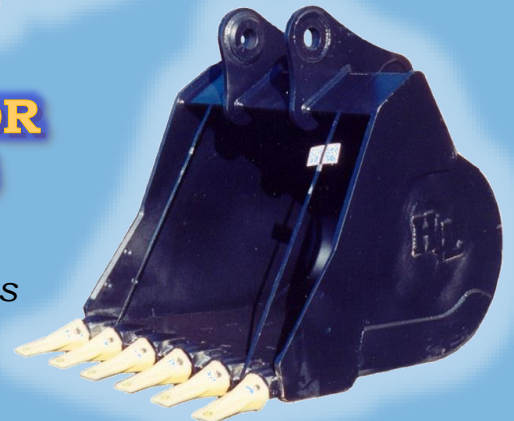

®Is a registered trademark of the respectively named Company.

All manufacturer's names, numbers, symbols and descriptions are used for reference purposes only.

# H&L® Style Scarifiers, Tooth and Flexpin®

©H&L Tooth Company 2024



**Most Popular Case Style Rippers**

**Millions of H&L® Scarifiers have been produced since 1944!**

Call Customer Service for all your GET requirements.

**Most Popular OEM G-163 Series Scarifiers**

**R-507-C-25**  
101.4#



**252ST**  
6.2#

**R-506-24**  
48.5#



**240ST**  
4.3#

**R-560-24**  
36.0#



**240ST**  
4.3#

Teeth are FORGED in the USA!

**G-163-BW-3/4**  
8.0#



**G-163-CD-3/4**  
8.0#



**G-163-HW-3/4**  
8.0#



**G-163-MS-3/4**  
6.0#

**G-163-DE-3/4**  
8.0#



Uses  
**1 3/4SP**  
1.03#

**G-950-21**  
Scarifier  
19.0#

Originally designed for International Harvester in 1953

**21SP**  
3.3#



**G-110-3/4**  
Scarifier  
8.6#

Originally designed for Allis-Chalmers in 1944

**1 3/4SP**  
1.03#



**G-1023-23**  
Scarifier  
22.0#

Originally designed for backhoe Ripping bucket in 1975.

Used with H&L® RH-2534-230 box.

**230ST**  
3.3#



**H&L® Original ... Smallest Scarifier in the World!**

**G-669-0**  
Scarifier  
1.1#

**OSP**  
0.3# Tooth



Dimensions can be found on our webpage under Scarifier Listings, flyer 68.2019a

## H&L® Forged Style Rippers

FORGED 18SP Tooth System since 1967

**18 SERIES**

Typical Small Ripper



**18FP**  
Flexpin®

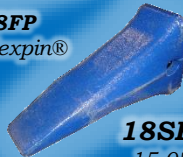

**18SP**  
15.0#  
Sharp Penetration



**19 SERIES**



**19-36FP**  
Flexpin®

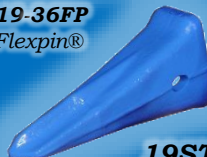

**19ST**  
27.5#  
Star Rib Design

FORGED 19ST Tooth System since 1975

ORIGINAL MODEL #	Ripper #	Weight	Width	Depth	Length	Holes
Cat D4, 941,951	RAC-850021-18	66.2#	2.25"	5.50"	21.25"	1
Fiat Allis D-11R	RG-828039-Y-18	270.0#	2.50"	10.00"	38.62"	2
I-Harvester 15R5	G-1024-A-18	98.0#	2.50"	5.50"	25.20"	2
I-Harvester 250R5	G-1024-B-18	105.0#	2.50"	5.50"	27.20"	2
I-Harvester TD-15R	RF-830031-18	158.0#	2.50"	7.50"	31.31"	2
I-Harvester TD-15R	RF-830034-18	175.0#	2.50"	7.50"	34.31"	2
Komatsu D-55S	RU-841034-18	150.0#	2.00"	7.25"	34.00"	3

ORIGINAL MODEL #	Ripper #	Weight	Width	Depth	Length	Holes
Cat 983	R-515-19	190.0#	2.88"	6.88"	35.00"	1
Cat D4, 941,951	RAC-850021-19	76.0#	2.25"	5.50"	21.75"	1
Cat D5, D6, 977	R-515-A-19	170.0#	2.88"	6.88"	30.00"	1
Cat D7	R-514-19	335.0#	2.88"	9.00"	45.38"	2
Fiat Allis FL20	R-529-19	320.0#	2.75"	8.88"	47.50"	2
I-Harvester TD-20	RG-829049-19	345.0#	2.50"	10.00"	48.70"	2
Komatsu D-85E	R-510-19	400.0#	2.88"	9.25"	52.00"	2
Komatsu D-85E	RL-834052-19	400.0#	2.88"	9.25"	52.00"	2



# H&L Style Large Rippers Shanks, Teeth and Flexpin®

©H&L Tooth Company 2024

## FORGED 36L SERIES



19-36FP  
Flexpin®



**36LST**  
33.0#  
Star Rib Design

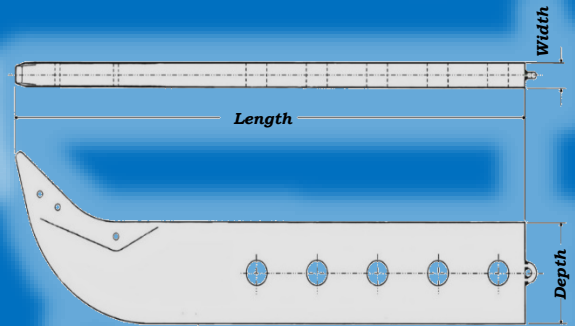

## All Makes and Models

36 Series  
Tooth System  
since 1960

H&L® style  
Ripper Shanks  
may not be a  
stocking item,  
call Customer  
Service to check  
availability.

MODEL #	Ripper #	Weight	Width	Depth	Length	Holes	Wear Plate
CAT D8N/8R/8T	RJ-814097-YU-36	1119.0#	2.94"	13.00"	96.22"	3	RX-2017
CAT D8N/8R/8T	RJ-812079-YU-36	854.0#	2.94"	13.00"	79.00"	3	RX-2017
CAT D8L	RJ-812075-YU-36	802.0#	2.94"	13.00"	74.62"	3	RX-2017
CAT D8H	RJ-810069-YU-36	750.0#	2.94"	13.00"	68.82"	2	RX-2017
CAT D8K	RJ-810062-YU-36	675.0#	2.94"	13.00"	61.82"	2	RX-2017
CAT D8L	RJ-809059-YU-36	644.0#	2.94"	13.00"	58.42"	2	RX-2017
CAT D9N/9R/9T	RJ-814109-YU-36	1196.0#	2.94"	13.00"	108.12"	3	RX-2017
CAT D9N/9T/9H	RJ-813092-YU-36	854.0#	2.94"	13.00"	91.27"	3	RX-2017
Fiat Allis HD-16R	R-403-YS-36	431.0#	2.88"	10.75"	47.00"	2	RX-1939
Fiat Allis HD-16R	RH-827047-YU-36	431.0#	2.88"	10.75"	47.00"	2	RX-1939
Fiat Allis HD-21R	R-513-BYS-36	706.0#	2.88"	13.00"	78.00"	3	RX-2017
Fiat Allis HD-21R	RJ-810078-YU-36	706.0#	2.88"	13.00"	78.00"	3	RX-2017
Fiat Allis HD-21R	R-353-Y3-36	555.0#	2.88"	13.00"	54.90"	3	RX-1930
Fiat Allis HD-21R	R-377-YS-36	555.0#	2.88"	13.00"	54.90"	3	RX-1939
Fiat Allis HD-21R	RJ-826055-YU-36	555.0#	2.88"	13.00"	54.90"	3	RX-2017
I-Harvester TD-25	R-476-CYS-36	630.0#	2.88"	13.00"	60.62"	2	RX-1939
I-Harvester TD-25	R-476-AYS-36	630.0#	2.88"	13.00"	60.62"	2	RX-2001
I-Harvester TD-25	R-517-YS-36	625.0#	2.88"	13.00"	60.62"	2	RX-2017
Komatsu D-155S	RJ-836065-YU-36	630.0#	2.88"	12.88"	65.00"	2	RX-2017
Komatsu D-155S	R-511-YS-36	630.0#	2.88"	12.00"	63.00"	2	RX-2017
Komatsu D-85S	R-510-YS-36	400.0#	2.88"	9.25"	52.00"	2	RX-2017



Saddle  
Style  
Wear Plate  
Shown

Single  
**FORGED**  
Ripper  
Shanks!

## Saddle Wear Plate Protectors and Flexpins



Wear Plate #	Weight	Width	Wear Plate Flexpin
RX-1930	72.0#	3.00"	Two RX-1926FP
RX-1939	43.0#	3.00"	Two RX-1926FP
RX-2001	31.0#	3.00"	Two RX-1926FP
RX-2017	43.0#	3.00"	Two RX-1926FP



Wear Plate  
Flexpin

® is a registered trademark of the respectively named Company.  
All manufacturer's names, numbers, symbols and descriptions are used for reference purposes only.

# H&L Style Large Rippers Shanks, Teeth and Flexpin®

©H&L Tooth Company 2024

## FORGED 38L SERIES



### Saddle Wear Plates



### Wear Plate Flexpins

Wear Plate #	Weight	Width	Wear Plate Flexpin
RX-1863	98.0#	3.62"	Two RX-1900FP
RX-1863C	98.0#	3.62"	Two RX-1900FP
RX-2146	180.0#	4.62"	Two RX-2647FP

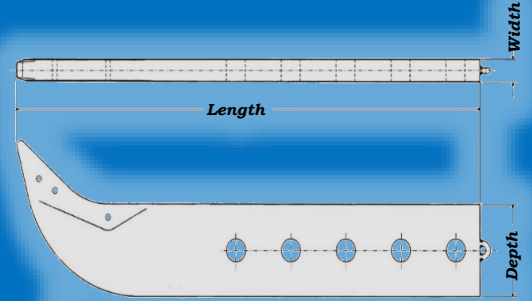

38 Series  
Tooth System  
since 1967

H&L® style  
Ripper Shanks  
may not be a  
stocking item,  
call Customer  
Service to check  
availability.



Saddle  
Style  
Wear Plate  
Shown

Single  
**FORGED**  
Ripper  
Shanks!

MODEL #	Ripper #	WT.	Width	Depth	Length	Holes	Wear Plate
Cat D10	RS-806110-YC-38	1960.0#	4.00"	15.75"	110.31"	4	RX-1863
Cat D10/D11N	RS-807078-YC-38	1381.0#	4.00"	15.75"	77.50"	2	RX-1863
CAT D9L/D10N	RP-861099-YC-38	1398.0#	3.50"	15.50"	98.81"	3	RX-1863
Cat D9L/D10	RN-862113-YC-38	1530.0#	3.50"	14.00"	113.00"	5	RX-1863
CAT D9L/D10N	RN-802111-YC-38	1409.0#	3.50"	14.00"	110.82"	3	RX-1863
Cat D8K/D9H	RN-804106-YC-38	1445.0#	3.50"	14.00"	105.92"	6	RX-1863
CAT D9L/D10N	RN-801091-YC-38	1236.0#	3.50"	14.00"	91.12"	3	RX-1863
CAT D9L/D10N/R/T	RN-866072-YC-38	962.0#	3.50"	14.00"	71.75"	2	RX-1863
CAT D9L/D10N	RN-805072-YC-38	962.0#	3.50"	14.00"	71.22"	2	RX-1863
Fiat Allis HD-31R	R-481-BYS-38	969.0#	3.50"	14.00"	71.50"	2	RX-1863
Fiat Allis HD-31R	R-481-YS-38	955.0#	3.50"	14.00"	71.50"	3	RX-1863
Fiat Allis HD-31R	R-522-BYS-38	969.0#	3.50"	14.00"	71.50"	2	RX-1863C
Fiat Allis HD-31R	R-522-YS-38	955.0#	3.50"	14.00"	71.50"	3	RX-1863
Fiat Allis HD-31R	RN-803072-YC-38	955.0#	3.50"	14.00"	71.50"	3	RX-1863
Fiat Allis HD-41R	R-531-AYS-38	1630.0#	4.50"	15.75"	83.00"	2	RX-2146
Fiat Allis HD-41R	RW-816082-YV-38	1630.0#	4.50"	15.75"	83.00"	2	RX-2146
Fiat Allis HD-41R	R-420-CYS-38	1172.0#	3.50"	15.50"	81.50"	3	RX-1863
Fiat Allis HD-41R	RP-824083-YC-38	1172.0#	3.50"	15.50"	81.50"	3	RX-1863C
Fiat Allis HD-41R	R-468-AYS-38	1102.0#	3.50"	15.50"	79.50"	2	RX-1863C
Fiat Allis HD-41R	RP-811074-YC-38	1102.0#	3.50"	15.50"	79.50"	2	RX-1863C
Fiat Allis HD-41R	RP-825075-YC-38	1107.0#	3.50"	15.50"	74.12"	3	RX-1863C
Fiat Allis HD-41R	R-420-YS-38	1107.0#	3.50"	15.50"	74.12"	3	RX-1863
I-Harvester TD-40	R-550-AYS-38	1750.0#	3.50"	15.25"	123.30"	4	RX-1863
I-Harvester TD-40	R-550-YS-38	1520.0#	3.50"	15.25"	108.30"	4	RX-1863
I-Harvester TD-40	R-496-YS-38	1110.0#	3.50"	15.25"	76.50"	2	RX-1863
Komatsu D-455	RY-838112-YV-38	2123.0#	4.38"	18.50"	112.00"	5	RX-2146
Komatsu D-455	R-521-YS-38	2166.0#	4.38"	18.50"	109.00"	5	RX-2146
Komatsu D-455	RV-839085-YC-38	1514.0#	3.75"	15.75"	85.00"	2	RX-1863
Komatsu D-375	RV-867088-YC-38	1558.0#	3.75"	15.75"	88.00"	3	RX-1863
Komatsu D-355	RV-840086-YC-38	1439.0#	3.75"	15.75"	86.38"	2	RX-1863
Komatsu D-355	R-535-YS-38	960.0#	3.50"	14.00"	72.75"	2	RX-1863
Komatsu D-355	RN-837073-YC-38	960.0#	3.50"	14.00"	72.75"	2	RX-1863

®Is a registered trademark of the respectively named Company.

All manufacturer's names, numbers, symbols and descriptions are used for reference purposes only.

# H&L Style Repair and Conversion Nosepieces

©H&L Tooth Company 2024

## FORGED Ripper Nosepiece!

### International-Harvester Special

#### RX-2000-YS-36

31.0#

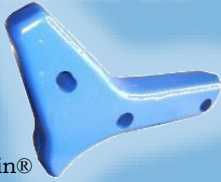

Uses  
36LST Tooth  
19-36FP Flexpin®  
RX-2001 Protector  
RX-1926FP (2) Flexpins

#### RX-1693-BUYS-36

210.0#



Uses  
36LST Tooth  
19-36FP Flexpin®  
RX-2017 Protector  
RX-1926FP (2) Flexpins

#### RX-2114-AKYS-38

400.0#



Uses  
38LST Tooth  
38FP Flexpin®  
RX-1963C Protector  
RX-1900FP (2) Flexpins

#### RX-1700-AKYS-308

450.0#



Uses  
308LST Tooth  
308FP Flexpin®  
RX-1863C Protector  
RX-1900FP (2) Flexpins

**308 Series  
CRC KELLY STYLE**

### Custom Repair Scarifier and Ripper Butt-Weld Style NP!



Nosepiece repair NP-23B, NP-24B, NP-25B, NP-27B, NP-18B, NP-19B, NP-31B, NP-32B, NP-33B, NP-36B, NP-38B and NP-308B Series Teeth.

*H&L® style Ripper Nosepieces are not a stocking item, call Customer Service to check availability.*

## H&L Back Up Ripper Shanks and Box Assemblies

Back-Up Ripper Systems since 1960

Side gussets or additional support plates may be required between bracket and mounting surfaces to give additional strength to the **Blade!**

**CAUTION:**  
Check all clearance that are required prior to final location and welding.

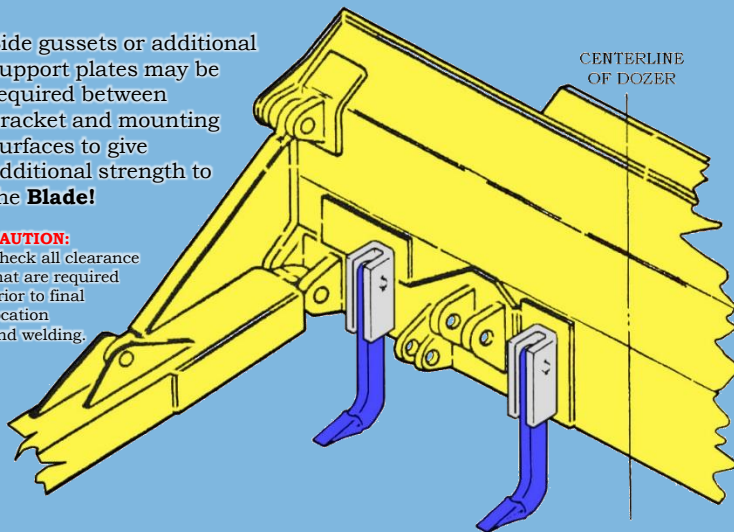

As the tractor moves forward, the ripper assembly drag freely behind the dozer blade and as the tractor moves to the rear each shank falls into the ripping position. Rippers become inoperative by simply raising the shank assembly up and inserting the pin in the "Back-Up Ripper" bracket.

*H&L® back-up Rippers are not a stocking item, call Customer Service to check availability.*

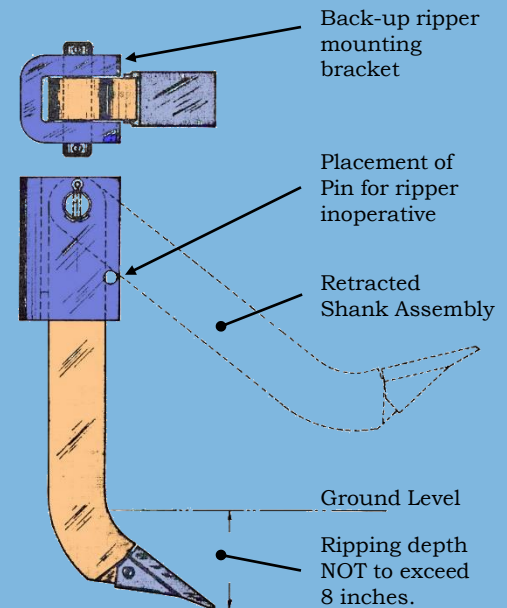

See "Flyer 35.2019" on hltooth.com webpage or ask H&L® Customer Service for a copy.

# H&L Backhoe Ripper Boxes Up to 4 Cubic Yard Buckets

©H&L Tooth Company 2024

*Bucket Ripper Box System since 1965*  
See "Flyer R001-2017" on hltooth.com webpage or ask H&L® Customer Service for added Details.

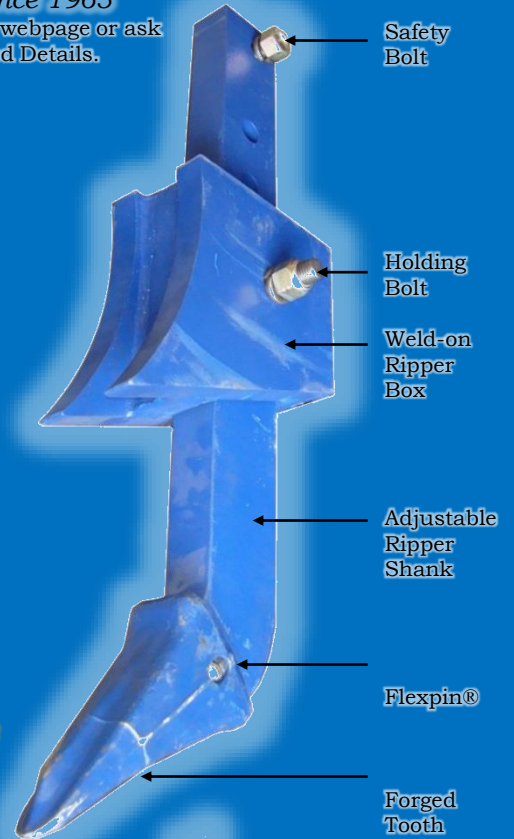
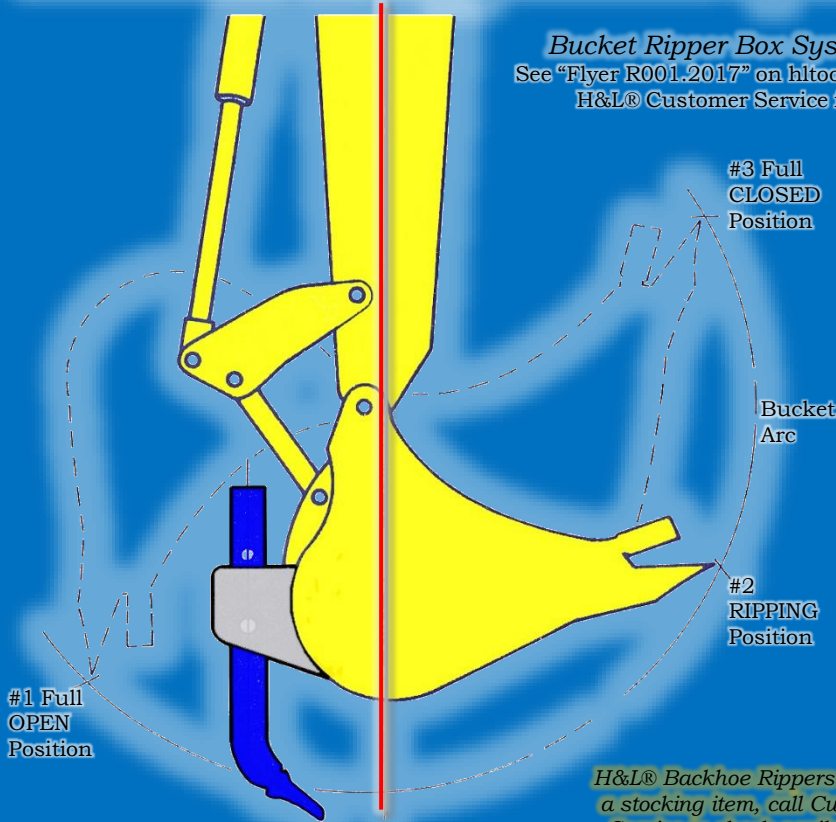

*H&L® Backhoe Rippers are not a stocking item, call Customer Service to check availability.*

**INSTALLATION:**

- Place centerline of "Dipper Stick" in vertical position.
- Rotate bucket from position #1 to position #3 to determine the "Bucket Arc".
- Open the bucket 1/3 the arc distance, this is position #2.
- Mount the ripper assembly to the rear of the bucket, making sure the ripper shank is aligned with the dipper stick centerline.

**All Backhoe Bucket Teeth are Uniforged® for added strength. Tooth sizes available 230ST, 240ST, 252ST, 18SP and 19ST.**

## H&L Tap-On Style Trencher Teeth and Pockets

**H&L® 11 and 12 Series Replaceable Tap-On style Teeth and weld-on Pockets.**

*11 and 12 Series Tooth System since 1964*

H&L® Tooth Company offers a wide range of sizes and style of Uniforged® heat treated trencher teeth to fit all your requirements.

See "Flyer 173.2019" on hltooth.com webpage or ask H&L® Customer Service for a copy.

**D-11 Pocket**

1.5#



**11-A Tooth**

0.8#



**D-12 Pocket**

3.0#

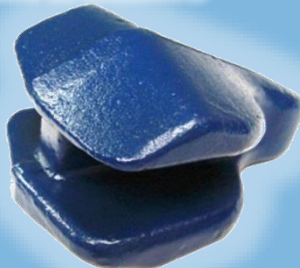

**12-B Tooth**

1.9#



See H&L Catalog #213.2022 for Pengo style FORGED #7, #9, #10 and other type Trencher Teeth!

**All 11 and 12 Tap-on Teeth and Pockets are FORGED in the USA!**

® is a registered trademark of the respectively named Company.

All manufacturer's names, numbers, symbols and descriptions are used for reference purposes only.

# H&L Style "VP" Vertical Pinned Teeth and Flexpin®

©H&L Tooth Company 2024



"VP" Series Tooth System since 1980

## 195VP Series

**195SP**

7.4#  
Limited Quantity



**195T**

8.2#



FORGED in the USA!

The VP system features a double locking vertical Flexpin® Tooth-to-Adapter connection. This patented system used on large mining Rope Shovels is now available for loaders and excavators.

## 205VP Series

**205SP**

9.5#



FORGED in the USA!

**205L**

10.5#



FORGED in the USA!

## "VP" Series Flexpins



## 315VP Series

**315SP**

14.0#  
Limited Quantity



**315L**

15.1#



FORGED in the USA!

Easy removal and installation, less replacement time resulting in shorter down time.

## 325VP Series

**325SP**

25.0#



FORGED in the USA!

**325L**

28.6#



FORGED in the USA!

Double locking "VP" vertical Flexpin® positive tooth-to-adapter connection!

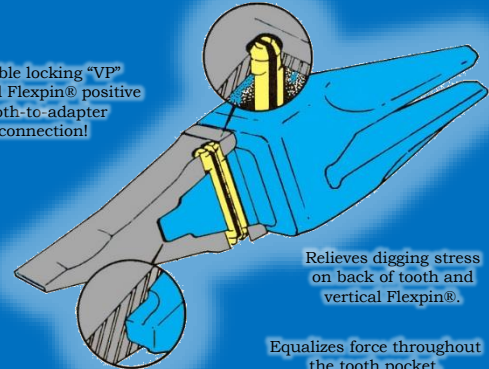

Relieves digging stress on back of tooth and vertical Flexpin®.

Equalizes force throughout the tooth pocket.

## 335VP Series

**335SP**

35.0#



FORGED in the USA!

**335A**

56.2#

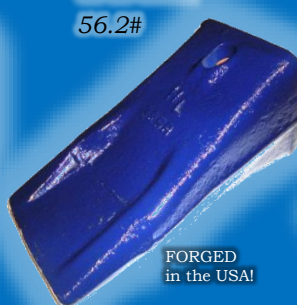

FORGED in the USA!

**335TT**

38.0#



FORGED in the USA!

®Is a registered trademark of the respectively named Company. All manufacturer's names, numbers, symbols and descriptions are used for reference purposes only.

# H&L Style "VP" Vertical Pinned Adapter Products

©H&L Tooth Company 2024



The VP system features a double locking vertical Flexpin® Tooth-to-Adapter connection. This patented system used on many large mining Rope Shovels for twenty-(20) years is now available for loaders and excavators.

## L-6001-BW-195

19.0#



.92" LIP  
Weld-On

Komatsu® Models:  
WA100, WA150, WA200,  
WA300, WA350

## L-6001-BW-205

19.0#



.92" LIP  
Weld-On

Komatsu® Models:  
WA100, WA150, WA200,  
WA300, WA350

## L-6032-A-195

27.0#

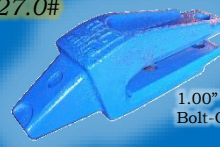

1.00" LIP  
Bolt-On

Komatsu® Models:  
WA180, WA200, D41S

## L-6032-A-205

27.0#

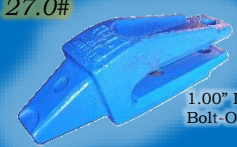

1.00" LIP  
Bolt-On

Komatsu® Models:  
WA180, WA200, D41S

## L-6003-A-205

27.0#

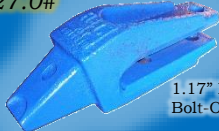

1.17" LIP  
Bolt-On

Komatsu® Models:  
WA250, WA260, WA300,  
WA320, D53S, D57-1

## L-6003-DA and EA-205

26.0#



1.17" LIP  
Bolt-On

Limited  
Quantity

Limited  
Quantity

Right and Left Corners

Komatsu® Models:  
WA250, WA260, WA300, WA320,  
D53S, D57-1

## LGT-6052-W-205

17.0#



1.25" LIP  
Weld-On

Case® Model:  
125B and a Variety of  
Rocky Mountain buckets

## L-6028-W-205

25.0#

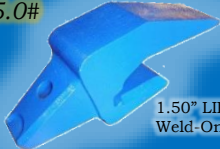

1.50" LIP  
Weld-On

Case® Model:  
125B and a Variety of  
Rocky Mountain buckets

## LGT-6028-W-315

25.0#



1.50" LIP  
Weld-On

Case® Model:  
170B and a Variety of  
Rocky Mountain buckets

## L-6033-AW-195

25.0#



1.50" LIP  
Weld-On

Case® Model:  
170B and a Variety of  
Rocky Mountain buckets

## L-6006-A-205

42.0#

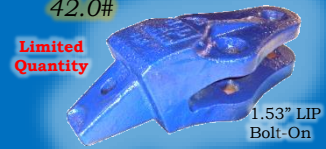

Limited  
Quantity

1.53" LIP  
Bolt-On

Komatsu® Models:  
WA280, WA350, WA35-IM,  
D75S, D75S-3, D75S-4

## L-6006-AW-205

25.0#



1.53" LIP  
Weld-On

Komatsu® Models:  
WA280, WA350, WA35-IM,  
D75S, D75S-3, D75S-4

## L-6006-315

50.0#

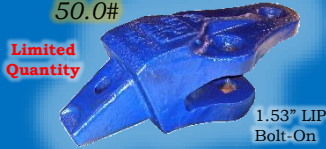

Limited  
Quantity

1.53" LIP  
Bolt-On

Komatsu® Models:  
WA280, WA350, WA35-IM,  
D75S, D75S-3, D75S-4

## L-6006-DA and EA-315

43.0#



1.53" LIP  
Bolt-On

Limited  
Quantity

Limited  
Quantity

Right and Left Corners

Komatsu® Models:  
WA250, WA260, WA300, WA320, D53S, D57-1

## L-6030-W-315

48.0#

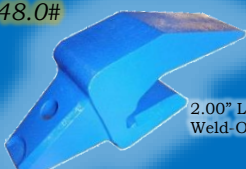

2.00" LIP  
Weld-On

Case® Model:  
125B and a Variety of  
Rocky Mountain buckets

## L-6030-AW-315

32.0#

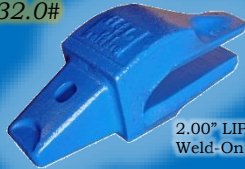

2.00" LIP  
Weld-On

Case® Model:  
220B and a Variety of  
Rocky Mountain buckets

## LGT-6030-W-325

39.0#



2.00" LIP  
Weld-On

Case® Model:  
220B and a Variety of  
Rocky Mountain buckets



®Is a registered trademark of the respectively named Company.

All manufacturer's names, numbers, symbols and descriptions are used for reference purposes only.

# H&L Pavement Breakers & Asphalt Cutters

©H&L Tooth Company 2024

Dimensional chart is for all H&L Pavement Breakers and Asphalt Cutters

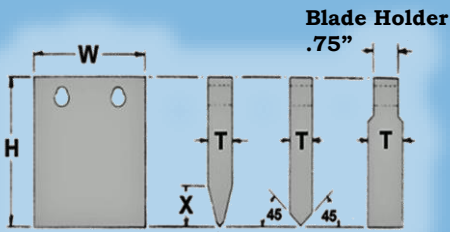

H&L's **Arrow Type** blade series are produced from aircraft quality Chrom-Moly grade alloy steel to enhance tool **DURABILITY** and **TOUGHNESS!**



Standard Tapered



Short Tapered



Heavy Blunt Hardfaced

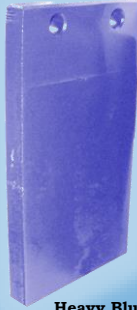

Heavy Blunt NOT Hardfaced



Heavy Blunt NOT Hardfaced



Typical Blade Holder

## .75" thick Pavement and Asphalt Blades

W	H	T	X	Std. Taper	Short Taper	Heavy Blunt
7.00"	8.44"	0.75"	2.50"	MX-994E	MX-994E-SH	MX-994E-BL
7.00"	10.00"	0.75"	2.50"	MX-994H	MX-994H-SH	MX-994H-BL
7.00"	12.00"	0.75"	2.50"	MX-994AC	MX-994AC-SH	MX-994AC-BL
7.00"	14.00"	0.75"	2.50"	MX-994AF	MX-994AF-SH	MX-994AF-BL
7.00"	16.00"	0.75"	2.50"	MX-994AN	MX-994AN-SH	MX-994AN-BL
8.00"	10.00"	2.00"	2.50"			MX-994S-BL
8.00"	16.00"	1.00"	2.50"			MX-994BJ-BL
10.00"	12.00"	0.75"	2.50"	MX-994AD	MX-994AD-SH	MX-994AD-BL
10.00"	14.00"	0.75"	2.50"	MX-994AG	MX-994AG-SH	MX-994AG-BL
12.00"	8.44"	0.75"	2.50"	MX-994G	MX-994G-SH	MX-994G-BL
12.00"	12.00"	0.75"	2.50"	MX-994P	MX-994P-SH	MX-994P-BL

All .75" **Heavy Blunt** asphalt blades are **Hardfaced!**

## 1.06" thick Pavement and Asphalt Blades

W	H	T	X	Std. Taper	Short Taper	Heavy Blunt
7.00"	10.00"	1.06"	2.75"	MX-1270F	MX-1270F-SH	MX-1270F-BL
7.00"	10.00"	1.06"	2.75"			MX-1270F-BLN
7.00"	14.00"	1.06"	2.75"			MX-1270G-BL
8.00"	10.00"	1.06"	2.75"			MX-1270H-BL
8.00"	10.00"	2.00"	2.75"			MX-1270J-BL
9.25"	8.00"	1.06"	2.75"			MX-1270K-BL
9.25"	10.00"	1.06"	2.75"	MX-1270C	MX-1270C-SH	MX-1270C-BL
9.25"	10.00"	1.06"	3.75"	MX-1270P		
10.00"	10.00"	1.06"	2.75"			MX-1270M-BL

All 1.06" **Heavy Blunt** asphalt blades are **Hardfaced!**

## .87" thick Pavement and Asphalt Blades

W	H	T	X	Std. Taper	Heavy Blunt
7.75"	11.00"	0.88"	2.50"	MAX-1671-11	MAX-1671-11BL
7.75"	12.00"	0.88"	2.50"	MAX-1671-12	
7.75"	16.00"	0.88"	2.50"	MAX-1671-16	MAX-1671-16BL
12.00"	11.00"	0.88"	2.50"	MAX-1672-11	MAX-1672-11BL
12.00"	21.00"	0.88"	2.50"	MAX-1672-21	
8.00"	11.00"	2.00"	2.50"		MAX-1673-11BL

All .88" **Heavy Blunt** asphalt blades are **NOT** Hardfaced!

## Other Product Catalogs

H&L® Caterpillar® Style Products: Catalog #210.2023

H&L® Cobra Style Products: Catalog #211.2024

H&L® Hensley® Style Products: Catalog #212.2023

H&L® Bobcat®, Komatsu® and Other Style Products: Catalog #213.2023

H&L® Whisler Mining & Ripper Products: Catalog #214.2023

H&L® Original 230-Series Products: Catalog #215.2024

H&L® Raw Steel Billet Ends: Catalog #223.2023

H&L® Original Fabricated Tooth Products: Catalog #242.2023

®Is a registered trademark of the respectively named Company.

All manufacturer's names, numbers, symbols and descriptions are used for reference purposes only.

# H&L® FACTORY WARRANTY!

*The H&L® Tooth Company warrants all H&L® Products against defects in material and workmanship.*

*Tulsa Oklahoma's 200,000 square foot manufacturing home includes forging, fabrication, and heat treating facilities, and serves as our central distribution complex.*



**Tulsa FORGE LINE consists of multiple 4"- 6"- 7 ½"- 9" National Upsetters, 1000, 1300, 2000 Ton National MaxiPress that will produce GET Products from 2 pounds to 2000 pounds.**



**Over two million GET parts in our Shipping Department in Tulsa, Oklahoma.  
H&L Tooth is an ISO 9001 CERTIFIED Company.**

**Patented  
Auto-Welders**

## H&L® Tooth Company Quality Policy

H&L® Tooth commits to meeting or exceeding internal and external customer requirements in its manufacturing and processing of ground engaging tools. This will be achieved by continually improving the effectiveness of our quality system through the establishment and tracking of quality objectives, identifying opportunities for improvements, and teamwork among our employees, customers and vendors.

**1-800-HLTOOTH**

**[www.hltooth.com](http://www.hltooth.com)**