

H&L Tooth Company
Quality **GET** since 1931

#209.2026 Catalog
A ISO 9001 CERTIFIED Company



Tooth Company Ground Engaging Tools

H&L® ORIGINAL OEM Wear Parts

Designed and Produced for:

•Cat® •Case® •Deere® •JCB® •New Holland® and Others

www.hltooth.com

**Forged Original
230SP
since
1957**



**Top Pin
233SP
Tooth**



233 Kliploc® Series

**Forged
201RE2D
Tooth**



RhombicGETsystems®

**Quality
GET since
1931**

**Triple Tiger®
for
all
23
Series
Adapters**



**H&L® Style
Flexpin®**



**H&L® Original
Trencher
Tap-On
Style
Teeth**



**230 and 201 Lip
Conversion**



**H&L®
Original
Forged
and
Cast
STAR 230ST**



**H&L®
1 3/4SP
Style
Scarifiers**



**The Original
Fabricated
Style
Teeth**



**Original
H&L®
Scarifier
and
Rippers**



**DeltaWing®
Patented
Lip Saver
23
Series
Teeth**



**H&L®
Backhoe
and
Excavator
Buckets**



**Bolt-On
Style
Adapters**



**H&L®
Backhoe
and
Back-Up
Rippers**



1-800-HL TOOTH

®Is a registered trademark of the respectively named Company.
All manufacturer's names, numbers, symbols and descriptions are used for reference purposes only.

Home of the H&L Tooth Company, Tulsa Oklahoma



200,000 square foot
manufacturing facility for
QUALITY FORGED WEAR PARTS
©H&L Tooth Company 2026

1-800-HL TOOTH (1-800-458-6684) • Visit us at www.hltooth.com



Page

Product Index

3

The Original **FORGED 230 Series Tooth System**.
Tooth styles SP, ST, CLAW, T, T9, TT and CTT.

4

The Original **Value-CAST 230 Series Line-up**. Tooth Styles
CSP, CST, TF, TR3, THD, TW, CF, CFC, CHF and CHFC.

5

230 Series Patented DeltaWing® Lip Saver Tooth System, SP-5, HD-5, T9-5
and TT7-5. **The Original 23SP Lite Duty Sharp Penetration** since 1931.

6

230 Series most popular Weld-on and selected Bolt-on Adapters.
Bottom strap, wrap around and flush mount styles available.

7

230 Series Flexpin® attaching Hardware... the 23FP, 23DLFP and 230DFP.
Patented 230 Series B230HL-1 **Pin Caddy® Removal Tool**.

8

Variety of 230 Series Tooth KITS

9

230 Patented DeltaWing® Series **LIP SAVER Tooth KITS**.
H&L's **233 Series Top Pin Kliploc® Hammerless Tooth System**.

10

H&L® Original CRIMP-ON Series fabricated OSP, 00SP, 2AH, 3CH
and 1 3/4SP teeth and adapter systems manufactured since 1941.

11

24-240 Series forged and cast Teeth, weld-on and bolt-on
Adapters with 24FP Flexpin® attaching hardware.

12

252 Series forged and cast Teeth with weld-on and bolt-on
Adapters with 25-26FP Flexpin® attaching hardware.

13

272 Series forged and cast Teeth with 20-27FP Flexpin® attaching hardware.
20 and 31 Series forged Teeth, adapters with Flexpin® attaching hardware.

14

32 and 33 Series forged Teeth, adapters with Flexpin® attaching hardware.
RhombicGETsystems® DRS style Teeth, weld-on and bolt-on adapters with Flexpin® hardware.

15

Bucket Lip Conversion utilizing H&L original 230 side pin or 201 DRS (diagonal pin) Teeth.
Backhoe Buckets... all Makes and Model. Butt-Weld repair or conversion **Nose Pieces**.

16

H&L® Scarifiers and Small Rippers using H&L original designed OSP, 21SP, 1 3/4SP,
230ST, 240ST, 252ST, 18SP and 19ST Series teeth with Flexpin® attaching hardware.

17

H&L® Style Rippers. 36LST Series for Cat, Fiat-Allis, International-Harvester, Komatsu and
Others by Model Numbers with ripper box sizes. Including Teeth, Flexpin® and Wear Protector.

18

H&L® Style Rippers. 38LST Series for Cat, Fiat-Allis, International-Harvester, Komatsu and
Others by Model Numbers with ripper box sizes. Including Teeth, Flexpin® and Wear Protector.

19

H&L® Ripper Repair and Conversion Nosepieces.
H&L® Back-Up Ripper Assemblies for all dozers equipment.

20

H&L® Backhoe and Excavator style Ripper Box Assemblies.
H&L® Original **11-Series and 12-Series** tap-on trencher Teeth and weld-on pockets.

21-22

H&L® "VP" Vertical, Teeth and Adapters. Original series from the 1980s...
195, 205, 315, 325 and 335 series teeth, adapters with attaching Flexpins®.

23

H&L® Pavement Breakers & Asphalt Cutters. H&L Allied Equipment for Blades on hydraulic
asphalt cutters and pavement breakers for Arrow Mfg. and Ottawa Hydra-Hammers

®Is a registered trademark of the respectively named Company.

All manufacturer's names, numbers, symbols and descriptions are used for reference purposes only.

230 Series Backhoe Teeth

230 Series, the Most Popular
Tooth in the World!



Forged 230 Series Line-up!

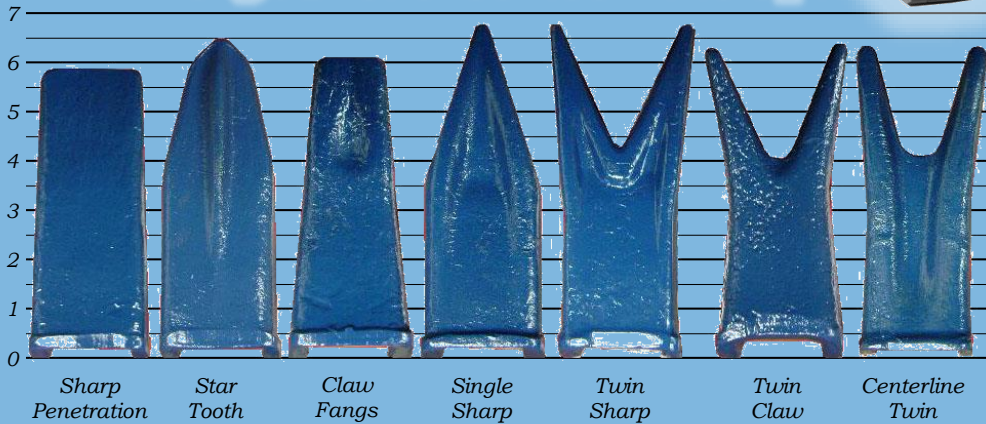

**STILL
FORGED IN
THE USA!**

Manufactured
Under Original
H&L® Patent
Specifications!

230SP Uses 23FP
2.6#

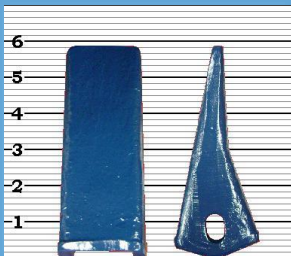

Sharp Penetration

- Uniforged® from tough Chrom-Moly aircraft grade steels.
- Hardened and tempered for optimum ductility!

230ST Uses 23FP
2.8#



Star Ripping Design

- Self-Sharpening Star design.
- Uniforged® from tough Chrom-Moly aircraft grade steels.

230T9 Uses 23FP
2.5#

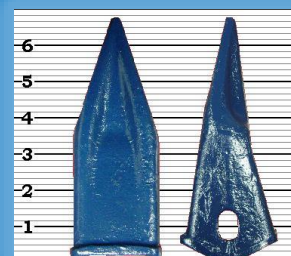

Single Sharp Design

- 20% Heavier than Competitor Dura casting!
- Uniforged® for exceptional strength.

230T Uses 23FP
2.7#

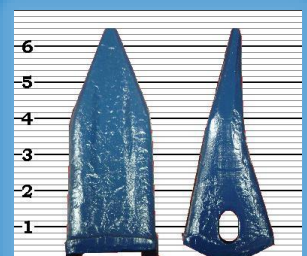

Single Sharp Design

- Uniforged® from tough Chrom-Moly aircraft grade steels.

230TT7 Uses 23FP
3.2#

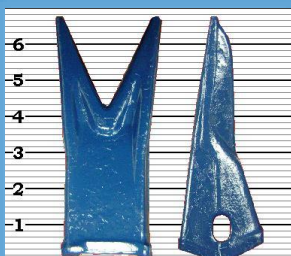

Twin Sharp Design

- 20% Heavier than Competitor Dura casting!
- Uniforged® for exceptional strength.

230CTT Uses 23FP
2.8#

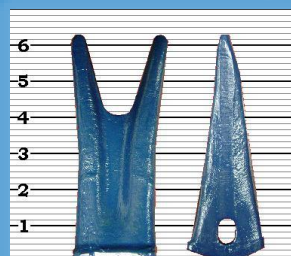

Centerline Twin Design

- Heavier tines enhances reliability and greater strength.

230TTCLAW Uses 23ODFP
3.2#

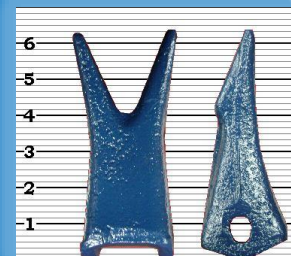

Twin Fangs Design

- "A unique curved design that lets the bucket dig with 23% less effort". The CLAW'S aggressive digging action delivers faster cycles and better bucket fill!

230CLAW Uses 23ODFP
2.9#

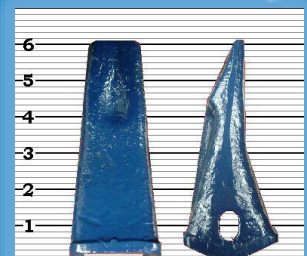

Claw Fangs Design

- "A unique curved design that lets the bucket dig with 23% less effort". The CLAW'S aggressive digging action delivers faster cycles and better bucket fill!

®Is a registered trademark of the respectively named Company. All manufacturer's names, numbers, symbols and descriptions are used for reference purposes only.

www.hltooth.com

230 Series Backhoe Teeth

Value-Cast 230 Series Line-up!



©H&L Tooth Company 2026

230CSP 2.7#

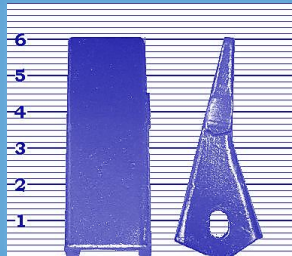

Cast Sharp Penetration Uses 23FP

●H&L® Factory Inspected for QUALITY.

230CST 2.6#

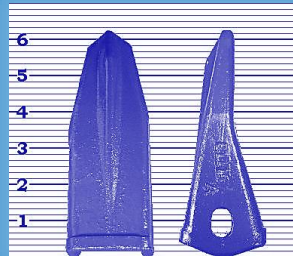

Cast Star Ripping Design Uses 23FP

●H&L® Factory Inspected for QUALITY.

230TF 3.9#

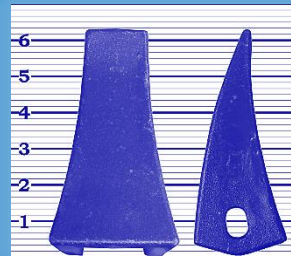

Cast Fangs TF23D Design Uses 23ODFP

●H&L® Factory Inspected for QUALITY.

230CPE 2.6#

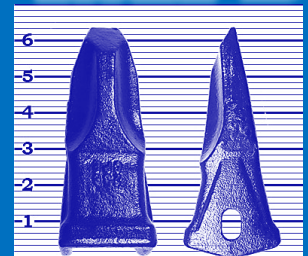

Cast Rock Penetrator Design Uses 23ODFP

●H&L® Factory Inspected for QUALITY.

230THD 3.1#

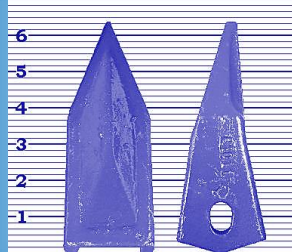

Cast Single Sharp Design Uses 23FP

●H&L® Factory Inspected for QUALITY.

230TL 2.1#

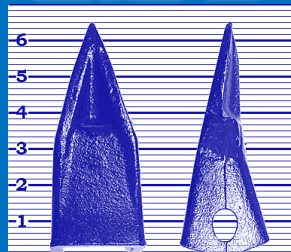

Cast Long Single Sharp Design Uses 23FP

●H&L® Factory Inspected for QUALITY.

230TW 3.9#

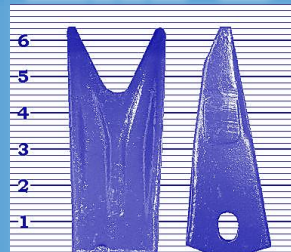

Cast Twin Sharp Design Uses 23FP

●H&L® Factory Inspected for QUALITY.

230WTL 2.4#

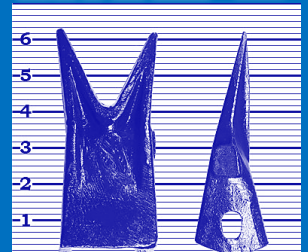

Cast Long Twin Sharp Design Uses 23FP

●H&L® Factory Inspected for QUALITY.

230TR3 4.5#

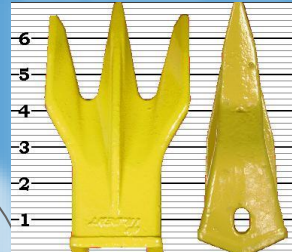

Patented Triple Tiger® Design Uses 23ODFP

●H&L® Factory Inspected for QUALITY.

230CF 3.5#

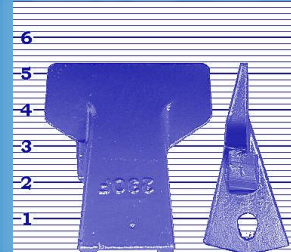

Cast Flared Tooth Uses 23FP

●H&L® Factory Inspected for QUALITY.

230CHF 4.0#

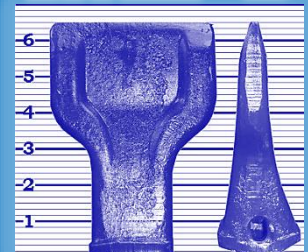

Cast Heavy Duty Flared Uses 23ODFP

●H&L® Factory Inspected for QUALITY.



WARRANTY

All H&L® Value-Cast products are factory inspected and covered under H&L's standard warranty program.



®Is a registered trademark of the respectively named Company.

All manufacturer's names, numbers, symbols and descriptions are used for reference purposes only.

230 Series DeltaWing® Lip Saving Teeth



H&L® Patented Lip Saver Tooth Systems!

Fits all 23-230 series field adapters!
Stops Flexpin® walking with a patented second lock in the tooth!

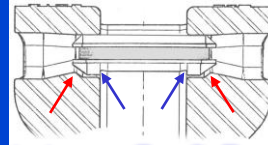

Protects your Case®, Deere®, DitchWitch®, JCB®, New Holland® and other buckets.



Increased bucket capacity!



No more lip wear scalloping!

230SP-5 3.2#



Sharp Penetration Lip Saver Teeth

- H&L® Factory Inspected for QUALITY.
- Patented secondary lock

230HD-5 3.8#

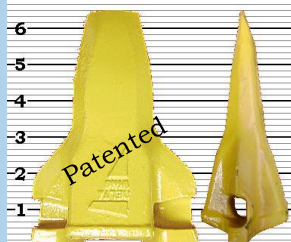

Heavy Duty Lip Saver Teeth

- H&L® Factory Inspected for QUALITY.
- Patented secondary lock

230T9-5 3.5#

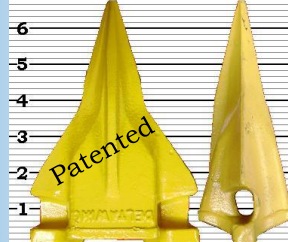

Single Tiger Lip Saver Teeth

- H&L® Factory Inspected for QUALITY.
- Patented secondary lock

230TT7-5 4.7#

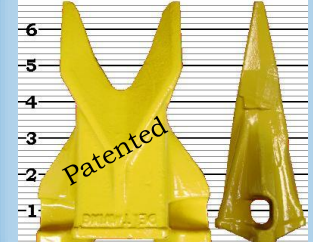

Twin Tiger Lip Saver Teeth

- H&L® Factory Inspected for QUALITY.
- Patented secondary lock

All H&L Products are WARRANTED against premature breakage!

“23SP” Sharp Penetration Tooth

H&L's Original Lite Duty Digging Tooth!

Still manufactured under original H&L® patent specifications since 1931!

23SP 2.1#



Sharp Penetration cast Tooth uses the Original 23FP Flexpin®



1-800-HL TOOTH

®Is a registered trademark of the respectively named Company.
All manufacturer's names, numbers, symbols and descriptions are used for reference purposes only.

23/230 Series Weld-On & Bolt-On Adapters

©H&L Tooth Company 2026

WELD-ON Mini Excavator Bottom Mount "1CW" Adapters

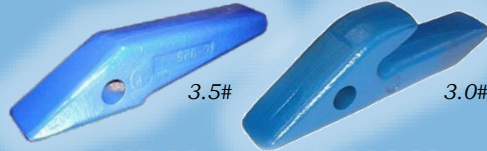

D-925-23
Up to 1.00" Lip

D-834-23
Up to 1.00" Lip

WELD-ON Tooth Bar Style "1W" Adapter

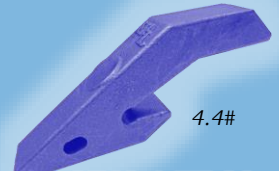

2740-AJW-23
1.56" Opening



OEM WELD-ON Backhoe Wrap Around "1W" Adapters

"Deep Dig" Center

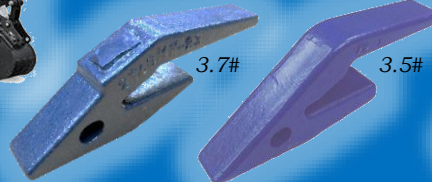

2740-MW-23
0.62" to 0.88" Lip

2740-AW-23
0.62" to 0.88" Lip

Case Style "Deep Dig" Center and Corner



2740-W-23
1.00" Lip

2740-ZW-23
1.00" Lip

2740-AFW-23
1.00" Lip

WELD-ON Top Mount "1BW" Adapters



L-4107-AJW-23
0.50" Lip

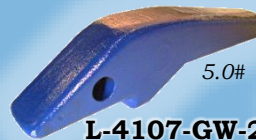

L-4107-GW-23
0.75" Lip



L-4107-AEW-23
0.88" Lip



L-4107-ARW-23
1.00" Lip



HL-1001-23
.75" Lip



**Bolt-on
HL-6737324-23**
0.75" to 1.00" Lip

WELD-ON REPAIR Nose Piece



1.74#

**230WN
Nosepiece**

MOST POPULAR BOLT-ON "1" Style Loader Adapters

H&L has designed many hundreds of Loader Adapters over the last nine decades. Give us a call with your specific dimensions.



**Typical Adapter
"1" Style**



**L-3445 series
Adapter "1" Style**



**L-3445-D-23 Adapter
"1A" Style**

Dimensional Review

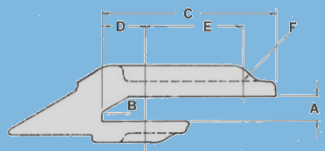

#1 Bolt-on Style Adapter

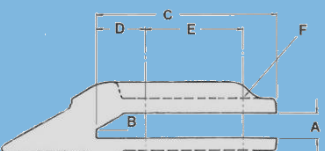

#1A Bolt-on Style Adapter

Adapter #	WT.	A	B	C	D	E	F	Style
L-4139-A-23	7.0#	0.50"	45°	6.25"	1.25"	3.00"	0.69"	1
L-3445-A-23	6.3#	0.62"	23°	5.88"	1.75"	3.00"	0.69"	1
L-4006-23	6.0#	0.75"	30°	6.25"	1.75"	3.00"	0.56"	1
L-4031-23	6.0#	0.75"	25°	6.50"	2.00"	3.00"	0.69"	1
L-3445-23	5.5#	0.75"	23°	6.50"	2.25"	3.00"	0.69"	1
L-3445-D-23	10.5#	0.75"	23°	6.12"	2.25"	3.00"	0.69"	1A
L-4193-23	5.0#	1.00"	30°	6.50"	2.00"	3.25"	0.69"	1
L-4275-23	5.0#	1.00"	23°	5.62"	2.44"	2.00"	0.56"	1

www.hltooth.com

® is a registered trademark of the respectively named Company.

All manufacturer's names, numbers, symbols and descriptions are used for reference purposes only.

23/230 Series Flexpins®

©H&L Tooth Company 2026

The Original 23FP Flexpin®

All Series Flexpins are built with sharp ends to ease installation!

BACK Halves of Flexpin® towards Bucket

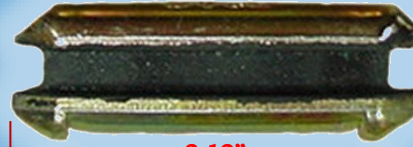

23DLFP Dual Lock Flexpin®

More locking powers for worn adapter installations!

230DFP DeltaWing Flexpin®

Ideal for Fangs, Triple Tiger® and Deltawing® teeth or worn assemblies requiring LONGER pins!

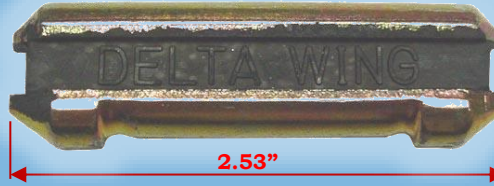

Art work published in 1952

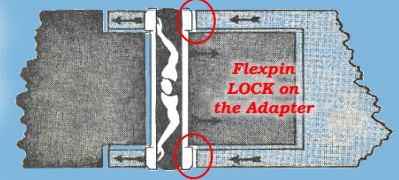

The H&L Flexpin® consists of two half-round lengths of steel with a section of live rubber vulcanized between to form an oval shaped pin. The compressed rubber forces the Flexpin® half-round sections in opposite directions. One half-round section bears on the nosepiece and the other bears only at each side of the tooth point to hold it securely on the adapter. See webpage for all Flexpin® updates and dimensions T163.2016.

230 SERIES PIN CADDY®

Installation and Remover Tool

B23HL1 Patented Tool for ALL 230-Series Teeth

Consists of
1-B23HL Tool
5-23FP Flexpins



Flexpin®
Installation



Pin Caddy®
Holds a
Complete Set
of Flexpins®



**REMOVE IT
FASTER!**

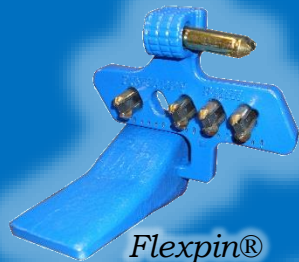

Flexpin®
Removal

FREE Flexpins



®Canada Trademark 1,349,309

®United States and Foreign Patents

1-800-HL TOOTH

230 Series Tooth KITS

©H&L Tooth Company 2026

KIT230SP 18.0#



Consists of 5-230SP and 5-23FP Flexpins

KIT230ST 19.0#



Consists of 5-230ST and 5-23FP Flexpins

KIT230CTT 19.0#



Consists of 5-230CTT and 5-23FP Flexpins

KIT230CLAW 19.5#



Consists of 5-230CLAW and 5-23DFP Flexpins

STILL FORGED IN THE USA!

“Cast-Value” Produced to H&Ls High Standards for QUALITY!

KIT230T9 18.0#



Consists of 5-230T9 and 5-23FP Flexpins

KIT230TT7 20.0#



Consists of 5-230TT7 and 5-23FP Flexpins

KIT230TTCLAW 19.0#



Consists of 5-230TTCLAW and 5-23DFP Flexpins

KIT230CSP 18.0#



Consists of 5-230CSP and 5-23FP Flexpins

KIT230CST 18.0#



Consists of 5-230CST and 5-23FP Flexpins

KIT230TW 21.5#



Consists of 5-230TW and 5-23FP Flexpins

KIT230TF 21.5#



Consists of 5-230TF and 5-23DFP Flexpins

KIT230THD 19.0#



Consists of 5-230THD and 5-23FP Flexpins

KIT230CF 21.5#



Consists of 5-230CF and 5-23FP Flexpins

KIT230CHF 22.0#



Consists of 5-230CHF and 5-23DFP Flexpins

KIT230TR3 24.0#



Consists of 5-230TR3, 5-23DFP Flexpins

The most popular tooth in the World!

www.hltooth.com

DeltaWing® TOOTH KITS

©H&L Tooth Company 2026

H&L® Patented Lip Saver Tooth Systems!

KIT230HD-5 21.5#



Consists of 5-230HD5, 5-230DFP Flexpins & 1-23RT

KIT230SP-5 19.0#



Consists of 5-230SP-5, 5-230DFP Flexpins & 1-23RT

KIT230TT7-5 24.0#



Consists of 5-230TT7-5, 5-230DFP Flexpins & 1-23RT

KIT230T9-5 21.5#



Consists of 5-230T9-5, 5-230DFP Flexpins & 1-23RT

Protects your Case®, Deere®, DitchWitch®, JCB®, New Holland® and other buckets utilizing 230-Series Teeth.

233 Series Top Pinning Kliploc®

Hammerless 233
an easy Top
Locking System

Direct Replacement for
Flexpin Style Teeth

Magically Converts Sidepin to Top Pin!



Only from the H&L Tooth Company, GET since 1931



ISO 9001 CERTIFIED Company

Fits All Existing 230 Series Adapters!

Search 233 on H&L webpage!

KIT233SP 22.0#



Consists of 5-233SP, 5-233CLP, 5-233Inserts

KIT233T9 19.1#



Consists of 5-233T9, 5-233CLP, 5-233Inserts

KIT233TT7 21.6#



Consists of 5-233TT7, 5-233CLP, 5-233Inserts

Fits Your Existing BACKHOE SHANKS!

Case®, Deere®, JCB® and Other Backhoe Shanks!

Please ask Customer Service to supply Punch at NO CHARGE when ordering!

No more "pin walking"! No more difficult side pin removal! No more special installation tools! No more front/back issues!

KIT233TF 26.0#



Consists of 5-233TF, 5-233CLP, 5-233Inserts

KIT233TR3 26.0#



Consists of 5-233TR3, 5-233CLP, 5-233Inserts

KIT233F 26.0#



Consists of 5-233F, 5-233CLP, 5-233Inserts



No more smashed finger injuries!

Manufactured under United States and foreign Patents

1-800-HL TOOTH

Fabricated CRIMP-ON Series Teeth and Adapters

©H&L Tooth Company 2026

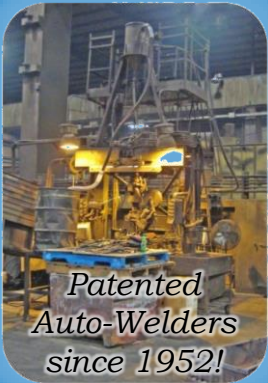

Patented Auto-Welders since 1952!

“OSP” Crimp-on Tooth System

OSP
0.3#

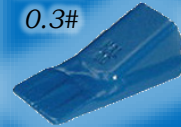

Sharp Penetration Fabricated Teeth

D-838-0 Adapter
0.5#

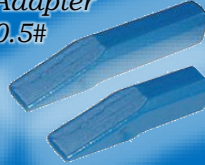

D-836-0 Adapter
0.4#

G-669-0 Scarifier
1.1#



“OOSP” Crimp-on Tooth System

OOSP
0.5#

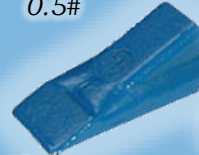

Sharp Penetration Fabricated Teeth

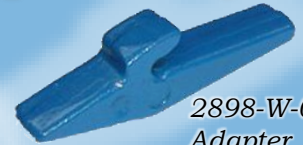

2898-W-00 Adapter
1.0#

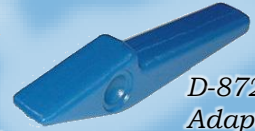

D-872-00 Adapter
1.1#

“2AH” Tooth and Adapter Crimp-on Style System

Designed and Manufactured since 1946!

2AH
0.9#



Sharp Penetration Fabricated Teeth



D-835-2A Adapter
2.0# **H&L Pin-on “2B” Adapters Available**



D-862-2A Adapter
1.6# **H&L Pin-on “2B” Adapters Available**



L-2520-BW-2A Adapter
1.9# **H&L Pin-on “2B” Adapters Available**

“3CH” Tooth and Adapter Crimp-on Style System

Designed and Manufactured since 1944!

3CHLR
1.8#



Sharp Penetration Fabricated Teeth

Limited Quantity Available

3CHW
2.4#



Wide Flared Fabricated Teeth



D-834-3C Adapter
3.0#

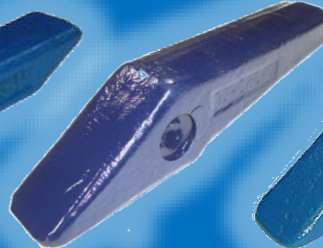

D-925-3C Adapter
3.5#



2740-JW-3C Adapter
3.0#

HL-8075SP

1.03#
Crimp-on or Pin-on



Designed and Manufactured since 1941!



1 3/4SP

1.03#
Crimp-on Only

Sharp Penetration Fabricated Teeth

H&L® Tooth offers a variety of scarifiers, search our webpage or call Customer Service.



G-163-BW-3/4 Shank
8.0#

G-163-HW-3/4 Shank
7.8#

G-163-CD-3/4 Shank
7.6#

“1 3/4SP” & HL-8075SP Tooth and Scarifier System

240 Series Teeth, Adapters and Flexpin®

©H&L Tooth Company 2026

24 and 240 Series Teeth

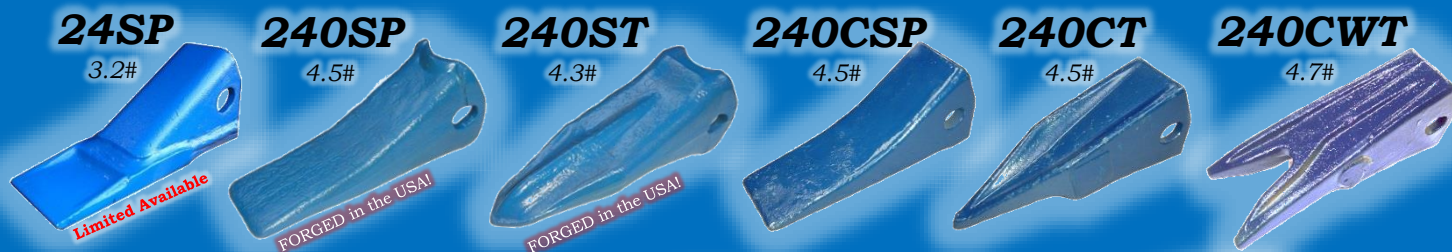

Backhoe WELD-ON "1CW" & "1W" Adapters



The Original 24FP Flexpin®

All Series Flexpins are built with sharp ends to ease installation!



The H&L® Flexpin® consists of two half-round lengths of steel with a section of live rubber vulcanized between to form an oval shaped pin. The compressed rubber forces the Flexpin® half-round sections in opposite directions. See webpage for all Flexpin® specifications and dimensions T163.2016.

MOST POPULAR 24-240 Series BOLT-ON Adapters

H&L Tooth offers a variety of 240 series adapters. Search our webpage or call Customer Service. Older OEM Style Adapters



Dimensional Review

H&L® has designed many hundreds of Loader Adapters over the last eight decades for many OEM. Give us a call with your specific dimensions.

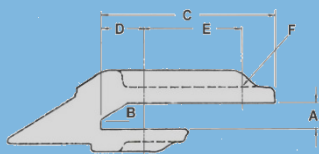

Typical Dimensions

Adapter #	WT.	A	B	C	D	E	F	Style
L-3445-D-24	6.5#	0.75"	23°	6.12"	2.25"	3.00"	0.69"	#3445
L-4252-24	9.0#	0.75"	22°	7.60"	2.48"	4.33"	0.81"	#1
L-3679-A-24	15.0#	1.00"	23°	7.75"	2.78"	3.75"	0.81"	#3679
L-3679-24	18.0#	1.00"	23°	7.85"	2.85"	3.75"	0.81"	#1A-COR
L-4108-BF-24	7.5#	1.00"	23°	7.00"	2.46"	3.50"	0.69"	#1B
L-4191-24	9.0#	1.00"	30°	7.62"	2.00"	4.62"	0.69"	#1
L-4128-24	8.5#	1.00"	30°	7.25"	2.50"	3.50"	0.69"	#1
L-4202-24	8.5#	1.25"	30°	7.25"	2.50"	3.50"	0.69"	#1
L-2021F-24	10.5#	1.25"	25°	7.38"	3.38"	3.00"	0.69"	#2021

®Is a registered trademark of the respectively named Company.

All manufacturer's names, numbers, symbols and descriptions are used for reference purposes only.

252 Series Teeth, Adapters and Flexpin®

©H&L Tooth Company 2026

252 Series Teeth



Backhoe WELD-ON "1CW" & "1W" Adapters



"1CW" Bottom Mount

"1W" Wrap Around

H&L® 25-26FP Flexpin®

All Series Flexpins are built with sharp ends to ease installation!



The H&L® Flexpin® consists of two half-round lengths of steel with a section of live rubber vulcanized between to form an oval shaped pin. The compressed rubber forces the Flexpin® half-round sections in opposite directions. See webpage for all Flexpin specification and dimensions T163.2016.



H&L Tooth offers a variety of 252 series adapters. Search our webpage or call Customer Service.

MOST POPULAR BOLT-ON Adapters

Older OEM Style Adapters



Dimensional Review

H&L® has designed many hundreds of Loader Adapters over the last eight decades for many OEM. Give us a call with your specific dimensions.

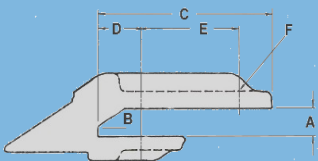

Typical Dimensions

Adapter #	WT.	A	B	C	D	E	F	Style
L-3637-A-25	25.5#	1.00"	23°	7.75"	2.78"	3.75"	0.81"	#3679
L-3637-25	20.0#	1.00"	23°	7.75"	2.78"	3.75"	0.81"	#1A-COR
L-3679-A-25	25.0#	1.00"	23°	7.75"	2.78"	3.75"	1.06"	#3679
L-3679-25	20.0#	1.00"	23°	7.75"	2.78"	3.75"	1.06"	#1A-COR
L-4052-25	12.0#	1.00"	30°	8.25"	2.12"	3.62"	0.69"	#1
L-4272-A-25	16.0#	1.25"	28°	7.25"	2.53"	3.50"	0.81"	#4272
L-3623-B-25	16.0#	1.25"	30°	7.00"	2.50"	3.50"	0.81"	#1A-COR
L-4279-25	25.0#	1.25"	30°	8.88"	3.50"	4.00"	0.81"	#1A
L-4194-25	10.0#	1.38"	23°	8.38"	3.38"	4.00"	0.81"	#1

®Is a registered trademark of the respectively named Company.

All manufacturer's names, numbers, symbols and descriptions are used for reference purposes only.

272 Series Teeth, Adapters and Flexpin®

272 Series Teeth

272SP

8.5#



FORGED in the USA!

272ST

9.3#



FORGED in the USA!

Excavator WELD-ON

“1CW”, “1W” & “1BW” Adapters

3000-W-27

1.88” Lip
13.0#



“1CW” Bottom Mount

2740-FW-27

1.50” Lip
11.0#



“1W” Wrap Around

L-4095-AW-27

1.50” Lip
20.0#

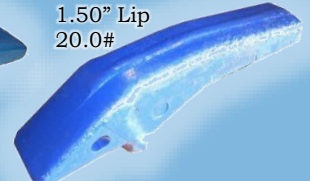

“1BW” Flush Mount

H&L® 20-27FP Flexpin®

All Series Flexpins are built with sharp ends to ease installation!



The H&L® Flexpin® consists of two half-round lengths of steel with a section of live rubber vulcanized between to form an oval shaped pin. The compressed rubber forces the Flexpin® half-round sections in opposite directions

See webpage for all Flexpin specifications and dimensions T163.2016.



20 and 31 Series Teeth, Adapters and Flexpin®

H&L Tooth offers a variety of 20 and 31 series adapters, most are custom and not stocked. Search our webpage or call Customer Service.

H&L® 20 Series Teeth and Weld-On Adapters are made for 1.25” to 1.75” in lip thickness, since 1963.

20SP

11.0#

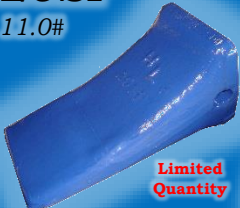

Limited Quantity

Sharp Penetration
FORGED in the USA!

20ST

11.8#

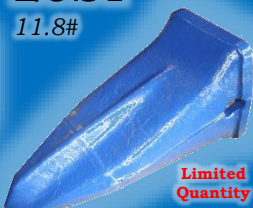

Limited Quantity

Star Tooth
FORGED in the USA!

L-4092 Series

25.0#

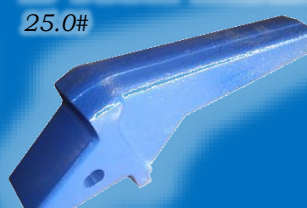

“1BW” Flush Mount

3000-W-20

18.0#

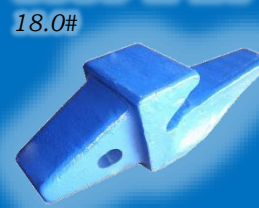

“1CW” Bottom Mount

20-27FP



H&L® 31 Series Teeth and Weld-On Adapters are made for 1.50” to 2.25” in lip thickness, since 1966.

31SP

20.2#



Limited Quantity

Sharp Penetration
FORGED in the USA!

31ST

21.4#



Limited Quantity

Star Tooth
FORGED in the USA!

L-4093 Series

40.0#



“1BW” Flush Mount

3000-W-31

28.0#



“1CW” Bottom Mount

31FP



1-800-HL TOOTH

®Is a registered trademark of the respectively named Company.

All manufacturer’s names, numbers, symbols and descriptions are used for reference purposes only.



32 and 33 Series Teeth, Adapters and Flexpin®

H&L® Tooth offers a variety of 32 and 33 series adapters, most are custom and not stocked. Search our webpage or call Customer Service.

H&L 32 Series Teeth and Weld-On Adapters are made for 1.75" to 2.50" in lip thickness, since 1963.

32SP
29.6#



Sharp Penetration
FORGED in the USA!

Limited Quantity

L-4094 Series
50.0#



"1BW" Flush Mount

3000-W-32
48.0#

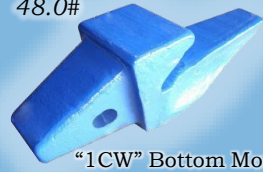

"1CW" Bottom Mount

32FP



H&L® 33 Series Teeth and Weld-On Adapters are made for 2.25" to 3.00" in lip thickness, since 1963.

33SP
43.4#



Sharp Penetration
FORGED in the USA!

Limited Quantity

33H
51.0#

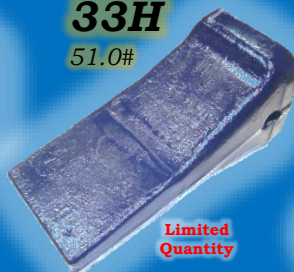

Heavy Rock Tooth
FORGED in the USA!

Limited Quantity

L-4173 Series
92.0#



"1BW" Flush Mount

3000-W-33
54.0#

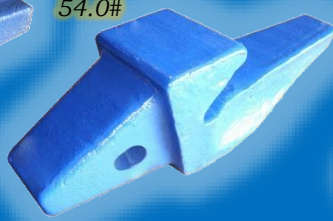

"1CW" Bottom Mount

33-35FP



RhombicGETsystem® - 136, 186 and 201 e-series

Diagonally Pinned Tooth System for Mini-Excavators, Skid-Steers, Backhoes

136RE2D
0.8#



186RE2D
2.0#



201RE2D
3.0#



FORGED in the USA!

201RE4
2.8#



FORGED in the USA!

201RE9
2.8#



FORGED in the USA!

201RE7
2.8#



FORGED in the USA!

RhombicGETsystem® are not interchangeable with Caterpillar® DRS Series Teeth!

"DRS" Style Weld-On & Bolt-On Adapters for Smaller Mini-Excavator Buckets

Mini-Excavator and Trenchers

D-835-136e
up to 1.25" Lip
2.0#

D-834-186e
up to 1.50" Lip
3.5#

136PN
Spiral Pin

186PN
Spiral Pin

L-3761-A-136e
Replaces 138-6410
0.38" Lip
2.0#

L-3760-A-186e
Replaces 135-9390
0.62" Lip
4.8#

Replacements for Uni-teeth

Skid-Steers and Backhoes

RhombicGETsystem® are manufactured under multiple United States and foreign PATENTS.

2740-ZW-201e
1.00" Lip
4.5#

230DFP
Flexpin®

Not interchangeable with Caterpillar® DRS-200

®Is a registered trademark of the respectively named Company.

All manufacturer's names, numbers, symbols and descriptions are used for reference purposes only.

BUCKET LIP CONVERSION 230 and 201e-series

©H&L Tooth Company 2026

Original 230 Series

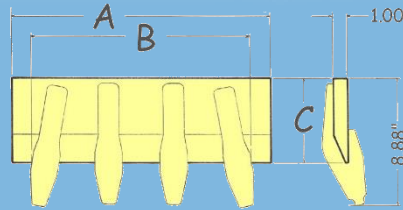

Lip chart dimensions are for reference purpose only!

Rhombic 201e Series



LIP NUMBER	WT.	A	B	C	TOOTH*
HL-12M480-230	32.0#	12.62"	10.69"	6.00"	230SP
HL-12M480-201e	32.0#	12.62"	10.69"	6.00"	201RE2D
HL-18M480-230	44.0#	18.50"	16.12"	6.00"	230SP
HL-18M480-201e	44.0#	18.50"	16.12"	6.00"	201RE2D
HL-24M480-230	59.0#	24.50"	22.31"	6.00"	230SP
HL-24M480-201e	59.0#	24.50"	22.31"	6.00"	201RE2D

**Forged Teeth Made in Tulsa, Oklahoma, United States of America!*

BACKHOE BUCKETS from H&L® Tooth!

Custom Repair Butt-Weld Style



Nosepiece repair
NP-23B, NP-24B,
NP-25B, NP-27B,
NP-18B, NP-19B,
NP-31B, NP-32B and
NP-33B Series Teeth.

**Many Makes and
Models in stock!**

**Unsurpassed Performance
and Reliability!**

*All bucket widths available
for Caterpillar®, Case®,
Deere®, JCB®, Komatsu®,
New Holland®
and other backhoe machines!*

FACTORY WARRANTY!



EXCAVATOR BUCKETS

*All Makes,
Models and Sizes*



H&L® Style Scarifiers, Tooth and Flexpin®

©H&L Tooth Company 2026



Most Popular Case Style Rippers

Millions of H&L® Scarifiers have been produced since 1944!

Call Customer Service for all your GET requirements.

Most Popular OEM G-163 Series Scarifiers

R-507-C-25
101.4#

R-506-24
48.5#

R-560-24
36.0#



252ST
6.2#

240ST
4.3#

240ST
4.3#

Teeth are FORGED in the USA!

G-163-BW-3/4
8.0#

G-163-CD-3/4
8.0#

G-163-HW-3/4
8.0#

G-163-MS-3/4
6.0#

G-163-DE-3/4
8.0#



Uses
1 3/4SP
1.03#

G-950-21
Scarifier
19.0#

Originally designed for International Harvester in 1953

G-110-3/4
Scarifier
8.6#

Originally designed for Allis-Chalmers in, 1944

1 3/4SP
1.03#

21SP
3.3#

G-1023-23
Scarifier
22.0#

Originally designed for backhoe Ripping bucket in 1975.

Used with H&L® RH-2534-230 box.

230ST
3.3#

H&L® Original ... Smallest Scarifier in the World!

G-669-0
Scarifier
1.1#

OSP
0.3# Tooth



Dimensions can be found on our webpage under Scarifier Listings, flyer 68.2019a

H&L® Forged Style Rippers

FORGED 18SP Tooth System since 1967

18 SERIES

Typical Small Ripper



18FP
Flexpin®

18SP
15.0#

Sharp Penetration



19 SERIES



19-36FP
Flexpin®

19ST
27.5#

Star Rib Design

ORIGINAL MODEL #	Ripper #	Weight	Width	Depth	Length	Holes
Cat D4, 941,951	RAC-850021-18	66.2#	2.25"	5.50"	21.25"	1
Fiat Allis D-11R	RG-828039-Y-18	270.0#	2.50"	10.00"	38.62"	2
I-Harvester 15R5	G-1024-A-18	98.0#	2.50"	5.50"	25.20"	2
I-Harvester 250R5	G-1024-B-18	105.0#	2.50"	5.50"	27.20"	2
I-Harvester TD-15R	RF-830031-18	158.0#	2.50"	7.50"	31.31"	2
I-Harvester TD-15R	RF-830034-18	175.0#	2.50"	7.50"	34.31"	2
Komatsu D-55S	RU-841034-18	150.0#	2.00"	7.25"	34.00"	3

FORGED 19ST Tooth System since 1975

ORIGINAL MODEL #	Ripper #	Weight	Width	Depth	Length	Holes
Cat 983	R-515-19	190.0#	2.88"	6.88"	35.00"	1
Cat D4, 941,951	RAC-850021-19	76.0#	2.25"	5.50"	21.75"	1
Cat D5, D6, 977	R-515-A-19	170.0#	2.88"	6.88"	30.00"	1
Cat D7	R-514-19	335.0#	2.88"	9.00"	45.38"	2
Fiat Allis FL20	R-529-19	320.0#	2.75"	8.88"	47.50"	2
I-Harvester TD-20	RG-829049-19	345.0#	2.50"	10.00"	48.70"	2
Komatsu D-85E	R-510-19	400.0#	2.88"	9.25"	52.00"	2
Komatsu D-85E	RL-834052-19	400.0#	2.88"	9.25"	52.00"	2

H&L Style Large Rippers Shanks, Teeth and Flexpin®

©H&L Tooth Company 2026

FORGED 36L SERIES



19-36FP
Flexpin®



36LST
33.0#
Star Rib Design

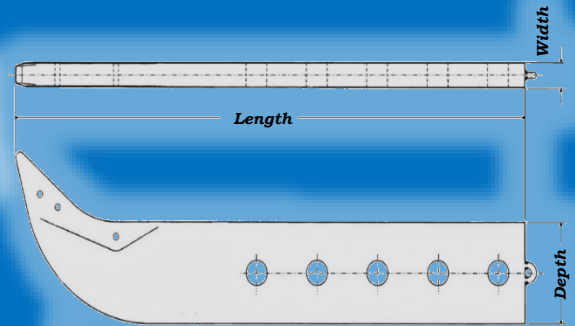

All Makes and Models

36 Series
Tooth System
since 1960

H&L® style
Ripper Shanks
may not be a
stocking item,
call Customer
Service to check
availability.

MODEL #	Ripper #	Weight	Width	Depth	Length	Holes	Wear Plate
CAT D8N/8R/8T	RJ-814097-YU-36	1119.0#	2.94"	13.00"	96.22"	3	RX-2017
CAT D8N/8R/8T	RJ-812079-YU-36	854.0#	2.94"	13.00"	79.00"	3	RX-2017
CAT D8L	RJ-812075-YU-36	802.0#	2.94"	13.00"	74.62"	3	RX-2017
CAT D8H	RJ-810069-YU-36	750.0#	2.94"	13.00"	68.82"	2	RX-2017
CAT D8K	RJ-810062-YU-36	675.0#	2.94"	13.00"	61.82"	2	RX-2017
CAT D8L	RJ-809059-YU-36	644.0#	2.94"	13.00"	58.42"	2	RX-2017
CAT D9N/9R/9T	RJ-814109-YU-36	1196.0#	2.94"	13.00"	108.12"	3	RX-2017
CAT D9N/9T/9H	RJ-813092-YU-36	854.0#	2.94"	13.00"	91.27"	3	RX-2017
Fiat Allis HD-16R	R-403-YS-36	431.0#	2.88"	10.75"	47.00"	2	RX-1939
Fiat Allis HD-16R	RH-827047-YU-36	431.0#	2.88"	10.75"	47.00"	2	RX-1939
Fiat Allis HD-21R	R-513-BYS-36	706.0#	2.88"	13.00"	78.00"	3	RX-2017
Fiat Allis HD-21R	RJ-810078-YU-36	706.0#	2.88"	13.00"	78.00"	3	RX-2017
Fiat Allis HD-21R	R-353-Y3-36	555.0#	2.88"	13.00"	54.90"	3	RX-1930
Fiat Allis HD-21R	R-377-YS-36	555.0#	2.88"	13.00"	54.90"	3	RX-1939
Fiat Allis HD-21R	RJ-826055-YU-36	555.0#	2.88"	13.00"	54.90"	3	RX-2017
I-Harvester TD-25	R-476-CYS-36	630.0#	2.88"	13.00"	60.62"	2	RX-1939
I-Harvester TD-25	R-476-AYS-36	630.0#	2.88"	13.00"	60.62"	2	RX-2001
I-Harvester TD-25	R-517-YS-36	625.0#	2.88"	13.00"	60.62"	2	RX-2017
Komatsu D-155S	RJ-836065-YU-36	630.0#	2.88"	12.88"	65.00"	2	RX-2017
Komatsu D-155S	R-511-YS-36	630.0#	2.88"	12.00"	63.00"	2	RX-2017
Komatsu D-85S	R-510-YS-36	400.0#	2.88"	9.25"	52.00"	2	RX-2017



Saddle
Style
Wear Plate
Shown

Single
FORGED
Ripper
Shanks!

Saddle Wear Plate Protectors and Flexpins



Wear Plate #	Weight	Width	Wear Plate Flexpin
RX-1930	72.0#	3.00"	Two RX-1926FP
RX-1939	43.0#	3.00"	Two RX-1926FP
RX-2001	31.0#	3.00"	Two RX-1926FP
RX-2017	43.0#	3.00"	Two RX-1926FP



Wear Plate
Flexpin

® is a registered trademark of the respectively named Company.
All manufacturer's names, numbers, symbols and descriptions are used for reference purposes only.

H&L Style Large Rippers Shanks, Teeth and Flexpin®

©H&L Tooth Company 2026

FORGED 38L SERIES



Saddle Wear Plates



Wear Plate Flexpins

Wear Plate #	Weight	Width	Wear Plate Flexpin
RX-1863	98.0#	3.62"	Two RX-1900FP
RX-1863C	98.0#	3.62"	Two RX-1900FP
RX-2146	180.0#	4.62"	Two RX-2647FP

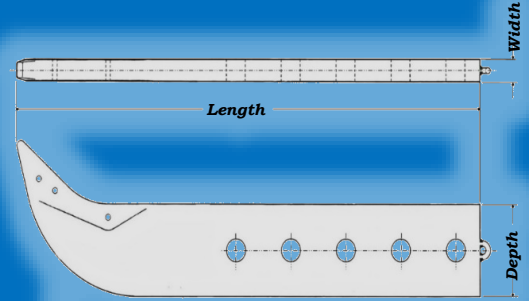

38 Series
Tooth System
since 1967

H&L® style
Ripper Shanks
may not be a
stocking item,
call Customer
Service to check
availability.



Saddle
Style
Wear Plate
Shown

Single
FORGED
Ripper
Shanks!

MODEL #	Ripper #	WT.	Width	Depth	Length	Holes	Wear Plate
Cat D10	RS-806110-YC-38	1960.0#	4.00"	15.75"	110.31"	4	RX-1863
Cat D10/D11N	RS-807078-YC-38	1381.0#	4.00"	15.75"	77.50"	2	RX-1863
CAT D9L/D10N	RP-861099-YC-38	1398.0#	3.50"	15.50"	98.81"	3	RX-1863
Cat D9L/D10	RN-862113-YC-38	1530.0#	3.50"	14.00"	113.00"	5	RX-1863
CAT D9L/D10N	RN-802111-YC-38	1409.0#	3.50"	14.00"	110.82"	3	RX-1863
Cat D8K/D9H	RN-804106-YC-38	1445.0#	3.50"	14.00"	105.92"	6	RX-1863
CAT D9L/D10N	RN-801091-YC-38	1236.0#	3.50"	14.00"	91.12"	3	RX-1863
CAT D9L/D10N/R/T	RN-866072-YC-38	962.0#	3.50"	14.00"	71.75"	2	RX-1863
CAT D9L/D10N	RN-805072-YC-38	962.0#	3.50"	14.00"	71.22"	2	RX-1863
Fiat Allis HD-31R	R-481-BYS-38	969.0#	3.50"	14.00"	71.50"	2	RX-1863
Fiat Allis HD-31R	R-481-YS-38	955.0#	3.50"	14.00"	71.50"	3	RX-1863
Fiat Allis HD-31R	R-522-BYS-38	969.0#	3.50"	14.00"	71.50"	2	RX-1863C
Fiat Allis HD-31R	R-522-YS-38	955.0#	3.50"	14.00"	71.50"	3	RX-1863
Fiat Allis HD-31R	RN-803072-YC-38	955.0#	3.50"	14.00"	71.50"	3	RX-1863
Fiat Allis HD-41R	R-531-AYS-38	1630.0#	4.50"	15.75"	83.00"	2	RX-2146
Fiat Allis HD-41R	RW-816082-YV-38	1630.0#	4.50"	15.75"	83.00"	2	RX-2146
Fiat Allis HD-41R	R-420-CYS-38	1172.0#	3.50"	15.50"	81.50"	3	RX-1863
Fiat Allis HD-41R	RP-824083-YC-38	1172.0#	3.50"	15.50"	81.50"	3	RX-1863C
Fiat Allis HD-41R	R-468-AYS-38	1102.0#	3.50"	15.50"	79.50"	2	RX-1863C
Fiat Allis HD-41R	RP-811074-YC-38	1102.0#	3.50"	15.50"	79.50"	2	RX-1863C
Fiat Allis HD-41R	RP-825075-YC-38	1107.0#	3.50"	15.50"	74.12"	3	RX-1863C
Fiat Allis HD-41R	R-420-YS-38	1107.0#	3.50"	15.50"	74.12"	3	RX-1863
I-Harvester TD-40	R-550-AYS-38	1750.0#	3.50"	15.25"	123.30"	4	RX-1863
I-Harvester TD-40	R-550-YS-38	1520.0#	3.50"	15.25"	108.30"	4	RX-1863
I-Harvester TD-40	R-496-YS-38	1110.0#	3.50"	15.25"	76.50"	2	RX-1863
Komatsu D-455	RY-838112-YV-38	2123.0#	4.38"	18.50"	112.00"	5	RX-2146
Komatsu D-455	R-521-YS-38	2166.0#	4.38"	18.50"	109.00"	5	RX-2146
Komatsu D-455	RV-839085-YC-38	1514.0#	3.75"	15.75"	85.00"	2	RX-1863
Komatsu D-375	RV-867088-YC-38	1558.0#	3.75"	15.75"	88.00"	3	RX-1863
Komatsu D-355	RV-840086-YC-38	1439.0#	3.75"	15.75"	86.38"	2	RX-1863
Komatsu D-355	R-535-YS-38	960.0#	3.50"	14.00"	72.75"	2	RX-1863
Komatsu D-355	RN-837073-YC-38	960.0#	3.50"	14.00"	72.75"	2	RX-1863

®Is a registered trademark of the respectively named Company.

All manufacturer's names, numbers, symbols and descriptions are used for reference purposes only.

H&L Style Repair and Conversion Nosepieces

©H&L Tooth Company 2026

International-Harvester Special

RX-2000-YS-36

31.0#

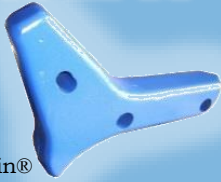

Uses
36LST Tooth
19-36FP Flexpin®
RX-2001 Protector
RX-1926FP (2) Flexpins

Custom Repair Scarifier and Ripper Butt-Weld Style NP!



Nosepiece repair NP-23B, NP-24B, NP-25B, NP-27B, NP-18B, NP-19B, NP-31B, NP-32B, NP-33B, NP-36B, NP-38B and NP-308B Series Teeth.

FORGED Ripper Nosepiece!

RX-1693-BUYS-36

210.0#



Uses
36LST Tooth
19-36FP Flexpin®
RX-2017 Protector
RX-1926FP (2) Flexpins

RX-2114-AKYS-38

400.0#



Uses
38LST Tooth
38FP Flexpin®
RX-1963C Protector
RX-1900FP (2) Flexpins

RX-1700-AKYS-308

450.0#



Uses
308LST Tooth
308FP Flexpin®
RX-1863C Protector
RX-1900FP (2) Flexpins

**308 Series
CRC KELLY STYLE**

H&L® style Ripper Nosepieces are not a stocking item, call Customer Service to check availability.

H&L Back Up Ripper Shanks and Box Assemblies

Back-Up Ripper Systems since 1960

Side gussets or additional support plates may be required between bracket and mounting surfaces to give additional strength to the **Blade!**

CAUTION:
Check all clearance that are required prior to final location and welding.

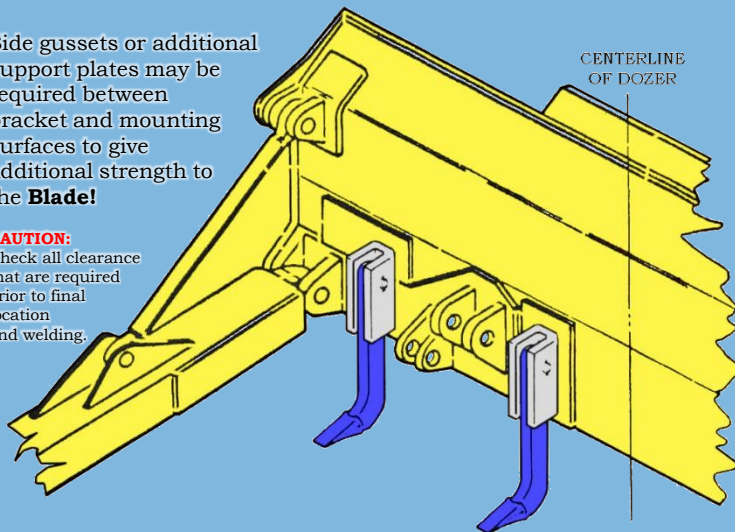

As the tractor moves forward, the ripper assembly drag freely behind the dozer blade and as the tractor moves to the rear each shank falls into the ripping position. Rippers become inoperative by simply raising the shank assembly up and inserting the pin in the "Back-Up Ripper" bracket.

H&L® back-up Rippers are not a stocking item, call Customer Service to check availability.

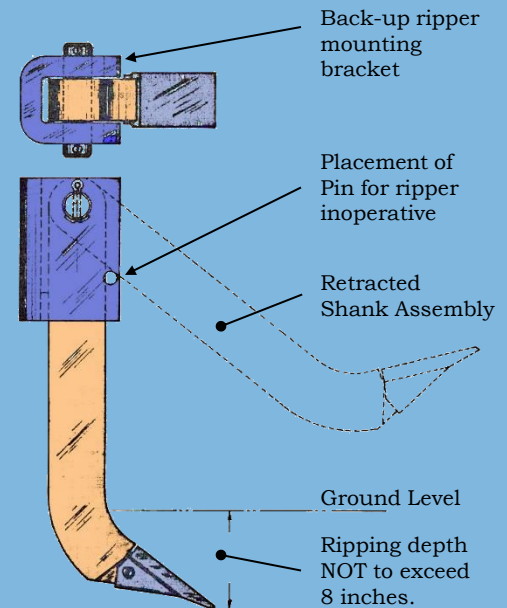

See "Flyer 35.2019" on hltooth.com webpage or ask H&L® Customer Service for a copy.

®Is a registered trademark of the respectively named Company.
All manufacturer's names, numbers, symbols and descriptions are used for reference purposes only.

H&L Backhoe Ripper Boxes Up to 4 Cubic Yard Buckets

©H&L Tooth Company 2026

Bucket Ripper Box System since 1965
See "Flyer R001.2017" on hltooth.com webpage or ask H&L® Customer Service for added Details.

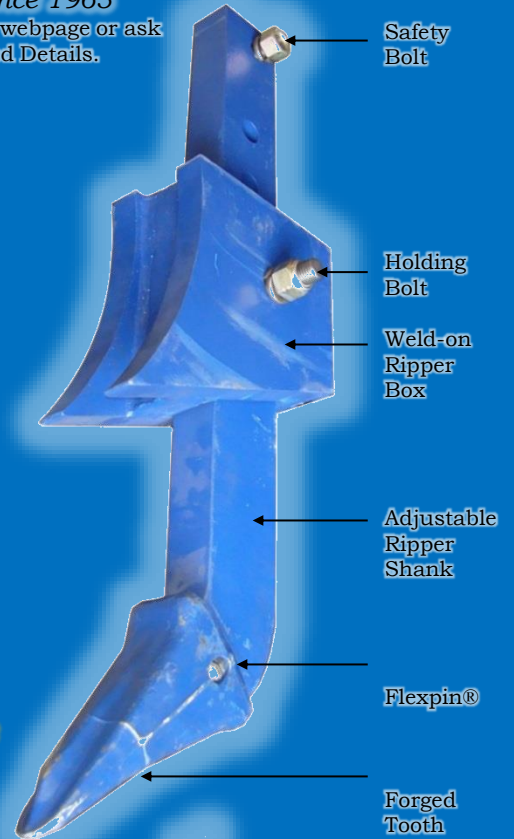
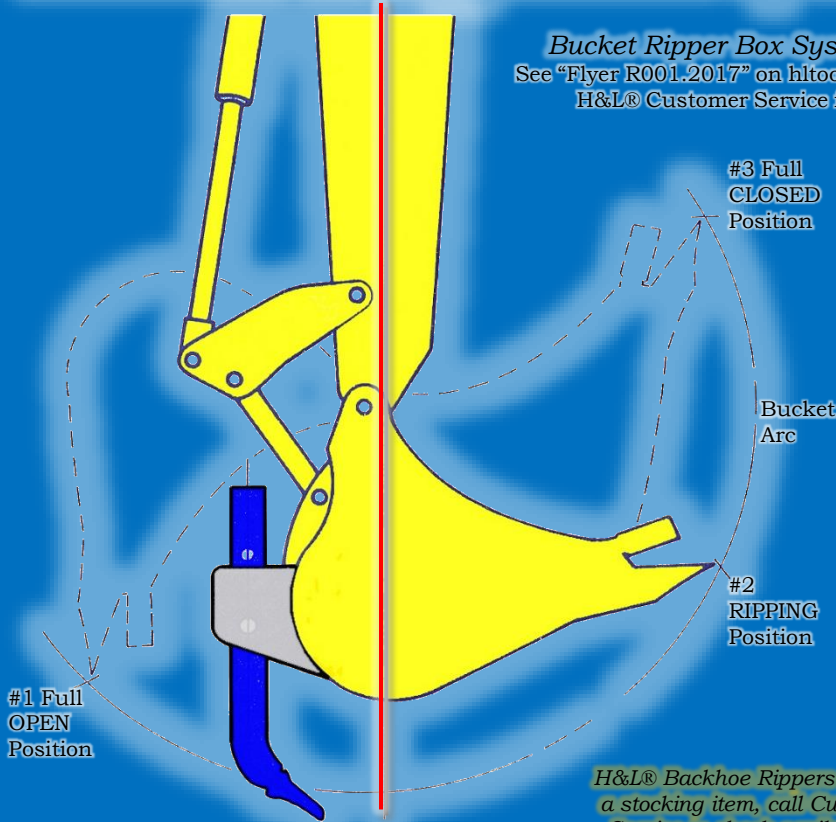

H&L® Backhoe Rippers are not a stocking item, call Customer Service to check availability.

INSTALLATION:

- Place centerline of "Dipper Stick" in vertical position.
- Rotate bucket from position #1 to position #3 to determine the "Bucket Arc".
- Open the bucket 1/3 the arc distance, this is position #2.
- Mount the ripper assembly to the rear of the bucket, making sure the ripper shank is aligned with the dipper stick centerline.

All Backhoe Bucket Teeth are Uniforged® for added strength. Tooth sizes available 230ST, 240ST, 252ST, 18SP and 19ST.

H&L Tap-On Style Trencher Teeth and Pockets

H&L® 11 and 12 Series Replaceable Tap-On style Teeth and weld-on Pockets.

11 and 12 Series Tooth System since 1964

H&L® Tooth Company offers a wide range of sizes and style of Uniforged® heat treated trencher teeth to fit all your requirements.

See "Flyer 173.2019" on hltooth.com webpage or ask H&L® Customer Service for a copy.

D-11 Pocket

1.5#



11-A Tooth

0.8#



D-12 Pocket

3.0#

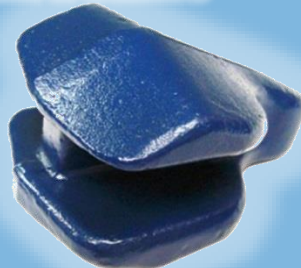

12-B Tooth

1.9#



See H&L Catalog #213.2022 for Pengo style FORGED #7, #9, #10 and other type Trencher Teeth!

All 11 and 12 Tap-on Teeth and Pockets are FORGED in the USA!

® is a registered trademark of the respectively named Company.

All manufacturer's names, numbers, symbols and descriptions are used for reference purposes only.

H&L Style "VP" Vertical Pinned Teeth and Flexpin®

©H&L Tooth Company 2026



"VP" Series Tooth System since 1980

195VP Series

195SP

7.4#
Limited Quantity



195T

8.2#



FORGED in the USA!

The VP system features a double locking vertical Flexpin® Tooth-to-Adapter connection. This patented system used on large mining Rope Shovels is now available for loaders and excavators.

205VP Series

205SP

9.5#



FORGED in the USA!

205L

10.5#



FORGED in the USA!

"VP" Series Flexpins



315VP Series

315SP

14.0#
Limited Quantity



315L

15.1#



FORGED in the USA!

Easy removal and installation, less replacement time resulting in shorter down time.

325VP Series

325SP

25.0#



FORGED in the USA!

325L

28.6#



FORGED in the USA!

Double locking "VP" vertical Flexpin® positive tooth-to-adapter connection!

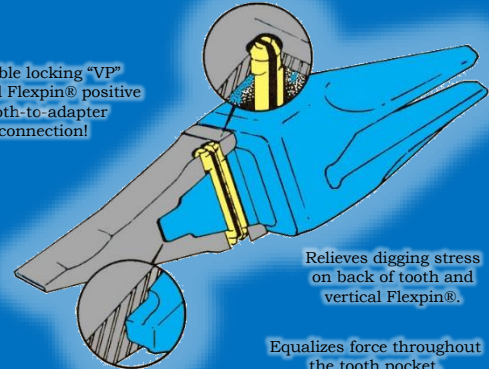

Relieves digging stress on back of tooth and vertical Flexpin®.

Equalizes force throughout the tooth pocket.

335VP Series

335SP

35.0#



FORGED in the USA!

335A

56.2#



FORGED in the USA!

335TT

38.0#



FORGED in the USA!

®Is a registered trademark of the respectively named Company. All manufacturer's names, numbers, symbols and descriptions are used for reference purposes only.

H&L Style "VP" Vertical Pinned Adapter Products

©H&L Tooth Company 2026



The VP system features a double locking vertical Flexpin® Tooth-to-Adapter connection. This patented system used on many large mining Rope Shovels for twenty-(20) years is now available for loaders and excavators.

L-6001-BW-195

19.0#



.92" LIP
Weld-On

Komatsu® Models:
WA100, WA150, WA200,
WA300, WA350

L-6001-BW-205

19.0#



.92" LIP
Weld-On

Komatsu® Models:
WA100, WA150, WA200,
WA300, WA350

L-6032-A-195

27.0#

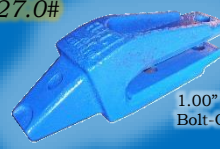

1.00" LIP
Bolt-On

Komatsu® Models:
WA180, WA200, D41S

L-6032-A-205

27.0#

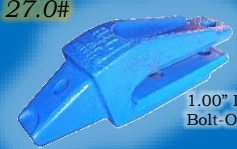

1.00" LIP
Bolt-On

Komatsu® Models:
WA180, WA200, D41S

L-6003-A-205

27.0#

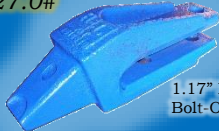

1.17" LIP
Bolt-On

Komatsu® Models:
WA250, WA260, WA300,
WA320, D53S, D57-1

L-6003-DA and EA-205

26.0#



1.17" LIP
Bolt-On

Limited
Quantity

Limited
Quantity

Right and Left Corners

Komatsu® Models:
WA250, WA260, WA300, WA320,
D53S, D57-1

LGT-6052-W-205

17.0#



1.25" LIP
Weld-On

Case® Model:
125B and a Variety of
Rocky Mountain buckets

L-6028-W-205

25.0#

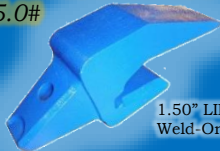

1.50" LIP
Weld-On

Case® Model:
125B and a Variety of
Rocky Mountain buckets

LGT-6028-W-315

25.0#



1.50" LIP
Weld-On

Case® Model:
170B and a Variety of
Rocky Mountain buckets

L-6033-AW-195

25.0#



1.50" LIP
Weld-On

Case® Model:
170B and a Variety of
Rocky Mountain buckets

L-6006-A-205

42.0#

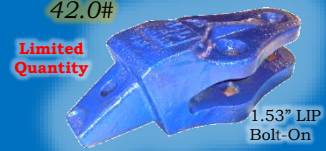

Limited
Quantity

1.53" LIP
Bolt-On

Komatsu® Models:
WA280, WA350, WA35-IM,
D75S, D75S-3, D75S-4

L-6006-AW-205

25.0#



1.53" LIP
Weld-On

Komatsu® Models:
WA280, WA350, WA35-IM,
D75S, D75S-3, D75S-4

L-6006-315

50.0#

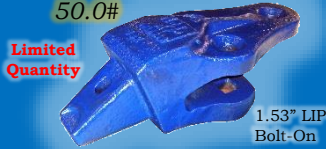

Limited
Quantity

1.53" LIP
Bolt-On

Komatsu® Models:
WA280, WA350, WA35-IM,
D75S, D75S-3, D75S-4

L-6006-DA and EA-315

43.0#



1.53" LIP
Bolt-On

Limited
Quantity

Limited
Quantity

Right and Left Corners

Komatsu® Models:
WA250, WA260, WA300, WA320, D53S, D57-1

L-6030-W-315

48.0#

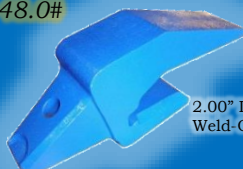

2.00" LIP
Weld-On

Case® Model:
125B and a Variety of
Rocky Mountain buckets

L-6030-AW-315

32.0#

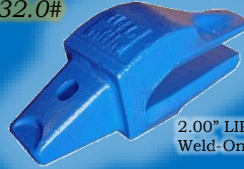

2.00" LIP
Weld-On

Case® Model:
220B and a Variety of
Rocky Mountain buckets

LGT-6030-W-325

39.0#



2.00" LIP
Weld-On

Case® Model:
220B and a Variety of
Rocky Mountain buckets



®Is a registered trademark of the respectively named Company.

All manufacturer's names, numbers, symbols and descriptions are used for reference purposes only.

H&L Pavement Breakers & Asphalt Cutters

©H&L Tooth Company 2026

Dimensional chart is for all H&L Pavement Breakers and Asphalt Cutters

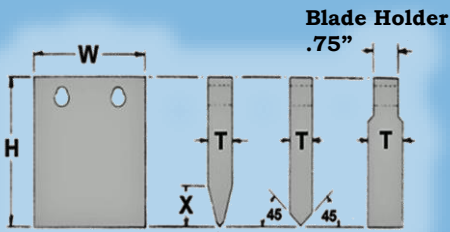

H&L's **Arrow Type** blade series are produced from aircraft quality Chrom-Moly grade alloy steel to enhance tool **DURABILITY** and **TOUGHNESS!**



Standard Tapered



Short Tapered



Heavy Blunt Hardfaced



Heavy Blunt NOT Hardfaced



Heavy Blunt NOT Hardfaced



Typical Blade Holder

.75" thick Pavement and Asphalt Blades

W	H	T	X	Std. Taper	Short Taper	Heavy Blunt
7.00"	8.44"	0.75"	2.50"	MX-994E	MX-994E-SH	MX-994E-BL
7.00"	10.00"	0.75"	2.50"	MX-994H	MX-994H-SH	MX-994H-BL
7.00"	12.00"	0.75"	2.50"	MX-994AC	MX-994AC-SH	MX-994AC-BL
7.00"	14.00"	0.75"	2.50"	MX-994AF	MX-994AF-SH	MX-994AF-BL
7.00"	16.00"	0.75"	2.50"	MX-994AN	MX-994AN-SH	MX-994AN-BL
8.00"	10.00"	2.00"	2.50"			MX-994S-BL
8.00"	16.00"	1.00"	2.50"			MX-994BJ-BL
10.00"	12.00"	0.75"	2.50"	MX-994AD	MX-994AD-SH	MX-994AD-BL
10.00"	14.00"	0.75"	2.50"	MX-994AG	MX-994AG-SH	MX-994AG-BL
12.00"	8.44"	0.75"	2.50"	MX-994G	MX-994G-SH	MX-994G-BL
12.00"	12.00"	0.75"	2.50"	MX-994P	MX-994P-SH	MX-994P-BL

All .75" **Heavy Blunt** asphalt blades are Hardfaced!

1.06" thick Pavement and Asphalt Blades

W	H	T	X	Std. Taper	Short Taper	Heavy Blunt
7.00"	10.00"	1.06"	2.75"	MX-1270F	MX-1270F-SH	MX-1270F-BL
7.00"	10.00"	1.06"	2.75"			MX-1270F-BLN
7.00"	14.00"	1.06"	2.75"			MX-1270G-BL
8.00"	10.00"	1.06"	2.75"			MX-1270H-BL
8.00"	10.00"	2.00"	2.75"			MX-1270J-BL
9.25"	8.00"	1.06"	2.75"			MX-1270K-BL
9.25"	10.00"	1.06"	2.75"	MX-1270C	MX-1270C-SH	MX-1270C-BL
9.25"	10.00"	1.06"	3.75"	MX-1270P		
10.00"	10.00"	1.06"	2.75"			MX-1270M-BL

All 1.06" **Heavy Blunt** asphalt blades are Hardfaced!

.87" thick Pavement and Asphalt Blades

W	H	T	X	Std. Taper	Heavy Blunt
7.75"	11.00"	0.88"	2.50"	MAX-1671-11	MAX-1671-11BL
7.75"	12.00"	0.88"	2.50"	MAX-1671-12	
7.75"	16.00"	0.88"	2.50"	MAX-1671-16	MAX-1671-16BL
12.00"	11.00"	0.88"	2.50"	MAX-1672-11	MAX-1672-11BL
12.00"	21.00"	0.88"	2.50"	MAX-1672-21	
8.00"	11.00"	2.00"	2.50"		MAX-1673-11BL

All .88" **Heavy Blunt** asphalt blades are **NOT** Hardfaced!

Other Product Catalogs

H&L® Caterpillar® Style Products: Catalog #210.2026

H&L® Cobra Style Products: Catalog #211.2026

H&L® Hensley® Style Products: Catalog #212.2026

H&L® Bobcat®, Komatsu® and Other Style Products: Catalog #213.2026

H&L® Whisler Mining & Ripper Products: Catalog #214.2026

H&L® Original 230-Series Products: Catalog #215.2026

H&L® Raw Steel Billet Ends: Catalog #223.2026

H&L® Original Fabricated Tooth Products: Catalog #242.2026

®Is a registered trademark of the respectively named Company.

All manufacturer's names, numbers, symbols and descriptions are used for reference purposes only.

H&L® FACTORY WARRANTY!

The H&L® Tooth Company warrants all H&L® Products against defects in material and workmanship.

Tulsa Oklahoma's 200,000 square foot manufacturing home includes forging, fabrication, and heat treating facilities, and serves as our central distribution complex.

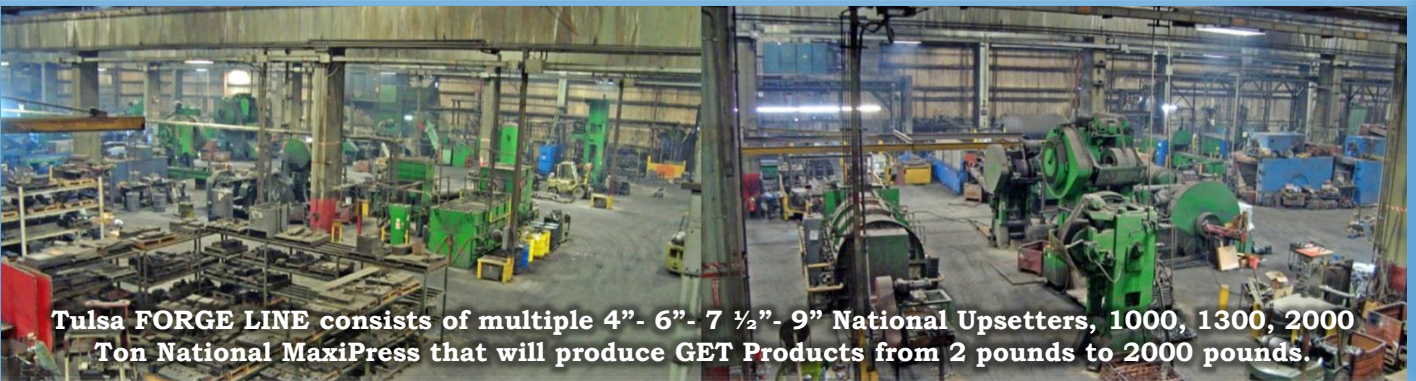

Tulsa FORGE LINE consists of multiple 4"- 6"- 7 ½"- 9" National Upsetters, 1000, 1300, 2000 Ton National MaxiPress that will produce GET Products from 2 pounds to 2000 pounds.



**Over two million GET parts in our Shipping Department in Tulsa, Oklahoma.
H&L Tooth is an ISO 9001 CERTIFIED Company.**

**Patented
Auto-Welders**

H&L® Tooth Company Quality Policy

H&L® Tooth commits to meeting or exceeding internal and external customer requirements in its manufacturing and processing of ground engaging tools. This will be achieved by continually improving the effectiveness of our quality system through the establishment and tracking of quality objectives, identifying opportunities for improvements, and teamwork among our employees, customers and vendors.

1-800-HLTOOTH

www.hltooth.com